

Pressure Measurement

Transmitters for basic requirements

SITRANS P MPS (submersible sensor) Transmitter for hydrostatic level

1

Overview



SITRANS P MPS pressure transmitters are submersible sensors for hydrostatic level measurements.

The SITRANS P MPS pressure transmitters are available for various measuring ranges and with explosion protection as an option.

A junction box and a cable hanger are available as accessories for simple installation.

Benefits

- Compact design
- Simple installation
- Small error in measurement (0,3 %)
- Degree of protection IP68

Application

SITRANS P MPS pressure transmitters are used in the following branches for example:

- Oil and gas industries
- Shipbuilding
- Water supply
- For use in pressureless/open tanks and wells

Design

SITRANS P MPS pressure transmitters have a front-flush piezo-resistive sensor with stainless steel diaphragm.

These pressure transmitters are equipped with an electronic circuit fitted together with the sensor in a stainless steel housing. The cable also contains a strength cord and vent pipe.

The diaphragm is protected against external influences by a protective cap.

The sensor, electronic circuit and cable are sealed in a common housing of small dimensions.

The pressure transmitter is temperature-compensated for a wide temperature range.

Function

SITRANS P MPS pressure transmitters are for measuring the liquid levels in wells, tanks, channels and dams.

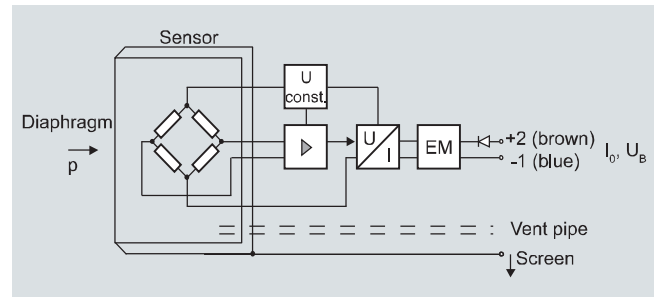

SITRANS P MPS pressure transmitter, mode of operation and wiring diagram

On one side of the sensor, the diaphragm is exposed to the hydrostatic pressure which is proportional to the submersion depth. This pressure is compared with atmospheric pressure. Pressure compensation is carried out using the vent pipe in the connection cable.

The hydrostatic pressure of the liquid column acts on the sensor diaphragm, and transmits the pressure to the piezo-resistive bridge in the sensor.

The output voltage of the sensor is applied to the electronic circuit where it is converted into an output current of 4 to 20 mA.

The cable of the 7MF1570 transmitter must always be connected in the supplied junction box. The junction box has to be installed near the measuring point.

If the medium is anything other than water, it is also necessary to check compatibility with the specified materials of the transmitter.

Integration

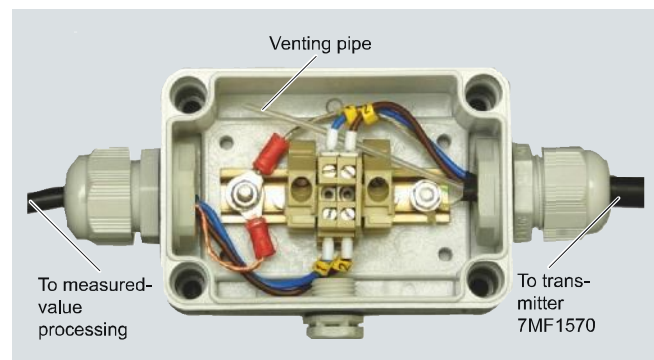

Junction box 7MF1570-8AA, opened

Pressure Measurement

Transmitters for basic requirements

SITRANS P MPS (submersible sensor) Transmitter for hydrostatic level

1



Measuring point setup, in principle

Technical specifications

SITRANS P MPS pressure measurement transmitter (submersible sensor)

Mode of operation

Measuring principle piezo-resistive

Input

Measured variable	Hydrostatic level
Measuring range	Maximum operating pressure
• 0 ... 2 mH ₂ O (0 ... 6 ftH ₂ O)	• 1.4 bar (20.3 psi) (corresponds to 14 mH ₂ O (42 ftH ₂ O))
• 0 ... 4 mH ₂ O (0 ... 12 ftH ₂ O)	• 1.4 bar (20.3 psi) (corresponds to 14 mH ₂ O (42 ftH ₂ O))
• 0 ... 5 mH ₂ O (0 ... 15 ftH ₂ O)	• 1.4 bar (20.3 psi) (corresponds to 14 mH ₂ O (42 ftH ₂ O))
• 0 ... 6 mH ₂ O (0 ... 18 ftH ₂ O)	• 3.0 bar (43.5 psi) (corresponds to 30 mH ₂ O (90 ftH ₂ O))
• 0 ... 10 mH ₂ O (0 ... 30 ftH ₂ O)	• 3.0 bar (43.5 psi) (corresponds to 30 mH ₂ O (90 ftH ₂ O))
• 0 ... 20 mH ₂ O (0 ... 60 ftH ₂ O)	• 5.0 bar (72.5 psi) (corresponds to 50 mH ₂ O (150 ftH ₂ O))

Output

Output signal 4 ... 20 mA

Measuring accuracy

Acc. to IEC 60770-1
Error in measurement at limit setting incl. hysteresis and reproducibility 0.3 % of full-scale value (typical)

Influence of ambient temperature

Zero and span
• 1 ... 6 mH₂O (3 ... 18 ftH₂O) 0.45 %/10 K of full-scale value
• ≥ 6 mH₂O (≥ 18 ftH₂O) 0.3 %/10 K of full-scale value

Long-term stability	
Zero and span	
• 1 ... 6 mH ₂ O (3 ... 18 ftH ₂ O)	0.25 % of full-scale value/year
• ≥ 6 mH ₂ O (≥ 18 ftH ₂ O)	0.2 % of full-scale value/year
Rated conditions	
Ambient conditions	
• Process temperature	-10 ... +80 °C (14 ... 176 °F)
• Storage temperature	-40 ... +100 °C (-40 ... +212 °F)
Degree of prot. to DIN EN 60529	IP68
Design	
Weight	
• Pressure transmitter	≈ 0.4 kg (≈ 0.88 lb)
• Cable	0.08 kg/m (≈ 0.054 lb/ft)
Electrical connection	
Cable with 2 conductors with screen and vent pipe, strength cord (max. 300 N (67.44 lbf))	
Material	
• Seal diaphragm	Stainl. steel, mat. no. 316L/316 Ti
• Enclosure	Stainl. steel, mat. no. 316L/316 Ti
• Gasket	Viton
• Connecting cable	Either PE/HFFR sheath (non-halogen) or FEP sheath
Power supply	
Terminal voltage on pressure transmitter U_B	10 ... 36 V DC
Certificates and approvals	
Germanischer Lloyd (GL)	GL 75360-09 HH
Bureau Veritas (BV)	BV 27101/A0 BV
Det Norske Veritas (DNV)	DNV A-12553
Drinking water approval (ACS)	ACS 11 ACC NY 014
Drinking water approval (WRAS)	WRAS 1111055
GOST	GOST-R, GOST FR.C.30.004.A/42376/1 und PPC 00-04 1505
The transmitter is not subject to the pressure equipment directive (PED 97/23/EC)	
Explosion protection	
• Intrinsic safety "I"	SEV 10 ATEX 0149
- Marking	II 1 G Ex ia IIC T4 Ga
Junction box	
Application	for connecting the transmitter cable
Design	
Weight	0.2 kg (0.44 lb)
Electrical connection	2 x 3-way (28 to 18 AWG)
Cable entry	2 x M20 x 1.5
Enclosure material	polycarbonate
Vent pipe for atmospheric pressure	
Screw for cable strength cord	
Rated conditions	
Degree of prot. to DIN EN 60529	IP65
Cable hanger	
Application	for mounting the transmitter
Design	
Weight	0.16 kg (0.35 lb)
Material	Galvanized steel, polyamide

Pressure Measurement

Transmitters for basic requirements

SITRANS P MPS (submersible sensor) Transmitter for hydrostatic level

1

Selection and Ordering data		Order No.	Order code	Selection and Ordering data		Order No.	Order code
SITRANS P MPS pressure transmitter for gauge pressure (submersible sensor)		7MF1570-	A0	SITRANS P MPS pressure transmitter for gauge pressure (submersible sensor)		7MF1570-	A0
2-wire system				2-wire system			
Note: Junction box and cable hanger included in delivery				Note: Junction box and cable hanger included in delivery			
With PE cable				With FEP cable			
Measuring range	Cable length L			Measuring range	Cable length L		
0 ... 2 mH ₂ O	10 m	▶	1 C	0 ... 2 mH ₂ O	10 m	▶	5 C
0 ... 4 mH ₂ O	10 m	▶	1 D	0 ... 4 mH ₂ O	10 m	▶	5 D
0 ... 5 mH ₂ O	25 m	▶	1 B	0 ... 5 mH ₂ O	25 m	▶	5 B
0 ... 6 mH ₂ O	25 m	▶	1 E	0 ... 6 mH ₂ O	25 m	▶	5 E
0 ... 10 mH ₂ O	25 m	▶	1 F	0 ... 10 mH ₂ O	25 m	▶	5 F
0 ... 20 mH ₂ O	25 m	▶	1 G	0 ... 20 mH ₂ O	25 m	▶	5 G
0 ... 6 ftH ₂ O	32 ft		1 K	0 ... 6 ftH ₂ O	32 ft		5 K
0 ... 12 ftH ₂ O	32 ft		1 L	0 ... 12 ftH ₂ O	32 ft		5 L
0 ... 18 ftH ₂ O	82 ft		1 M	0 ... 18 ftH ₂ O	82 ft		5 M
0 ... 30 ftH ₂ O	82 ft		1 N	0 ... 30 ftH ₂ O	82 ft		5 N
0 ... 60 ftH ₂ O	82 ft		1 P	0 ... 60 ftH ₂ O	82 ft		5 P
Special cable length/Special measuring range ¹⁾			9 A	Special cable length/Special measuring range ¹⁾			9 A
Please add „-Z“ to Order No. and specify Order code and plain text.			Y 0 1	Please add „-Z“ to Order No. and specify Order code and plain text.			Y 0 1
Note: Indication of measuring range Y01 is always necessary.				Note: Indication of measuring range Y01 is always necessary.			
3 m			H 1 A	3 m			H 5 A
5 m			H 1 B	5 m			H 5 B
7 m			H 1 C	7 m			H 5 C
10 m			H 1 D	10 m			H 5 D
15 m			H 1 E	15 m			H 5 E
20 m			H 1 F	20 m			H 5 F
25 m			H 1 G	25 m			H 5 G
30 m			H 1 H	30 m			H 5 H
40 m			H 1 J	40 m			H 5 J
50 m			H 1 K	50 m			H 5 K
60 m			H 1 L	60 m			H 5 L
70 m			H 1 M	70 m			H 5 M
80 m			H 1 N	80 m			H 5 N
90 m			H 1 P	90 m			H 5 P
100 m			H 1 Q	100 m			H 5 Q
125 m			H 1 R	125 m			H 5 R
150 m			H 1 S	150 m			H 5 S
175 m			H 1 T	175 m			H 5 T
200 m			H 1 U	200 m			H 5 U
225 m			H 1 V	225 m			H 5 V
250 m			H 1 W	250 m			H 5 W
275 m			H 1 X	275 m			H 5 X
300 m			H 2 A	300 m			H 6 A
350 m			H 2 B	350 m			H 6 B
400 m			H 2 C	400 m			H 6 C
450 m			H 2 D	450 m			H 6 D
500 m			H 2 E	500 m			H 6 E
550 m			H 2 F	550 m			H 6 F
600 m			H 2 G	600 m			H 6 G
650 m			H 2 H	650 m			H 6 H
700 m			H 2 J	700 m			H 6 J
750 m			H 2 K	750 m			H 2 K
800 m			H 2 L	800 m			H 6 L
850 m			H 2 M	850 m			H 6 M
900 m			H 2 N	900 m			H 6 N
950 m			H 2 P	950 m			H 6 P
1000 m			H 2 Q	1000 m			H 6 Q

Pressure Measurement

Transmitters for basic requirements

SITRANS P MPS (submersible sensor) Transmitter for hydrostatic level

1

Selection and Ordering data	Order No.	Order code
SITRANS P MPS pressure transmitter for gauge pressure (submersible sensor)	7MF1570 -	A 0
2-wire system		
Note: Junction box and cable hanger included in delivery		
Explosion protection		
• None		1
• with type of protection "intrinsic safety" (Ex II 1 G Ex ia IIC T4)		2
Approvals		
• with drinking water approval to WRAS and ACS		6
Further designs	Order code	
Quality inspection certificate (factory calibration) to IEC 60770-2, add „-Z“ to order no. and add order code.	C11	
Indication of measuring range (only at special cable lengths) in „... to ... mH ₂ O“ or „... to ... ftH ₂ O“	Y01	
Accessories (as spare part)	Order No.	
Junction box for connecting the transmitter cable	7MF1570-8AA	
Cable hanger for attachment of transmitter	7MF1570-8AB	

► Available ex stock

Power supply units see Chap. 7 "Supplementary Components".

1) Special measuring ranges of between 0 ... 1 mH₂O (0 ... 3 ftH₂O) and 0 ... 200 mH₂O (0 ... 656 ftH₂O) and special cable lengths of up to 1000 m (3281 ft) are possible. With Ex versions the max. custom cable length is 50 m (150 ft). The length of free hanging cable should not exceed 375 m (1230 ft).

Note: Due to mounting reasons it has to be considered that the cable always must be longer than the height of the liquid column to be measured.

Dimensional drawings

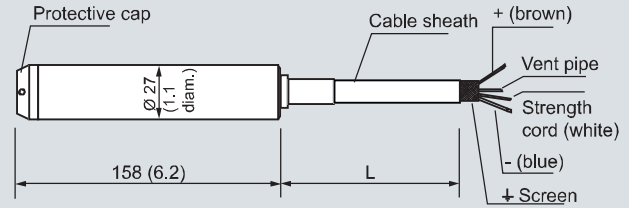

Cable sheath 8.3 (0.33) diam. (black or blue, PE/HFFR)
Flexible cable with 0.5 mm² (0.00078 inch²) cross-section
Vent pipe 1 (0.04) diam. (inner diameter)
Protective cap with 4 x 3 diam. (4 x 0.12 diam.) holes (black, PA)

SITRANS P MPS pressure transmitters, dimensions in mm (inch)

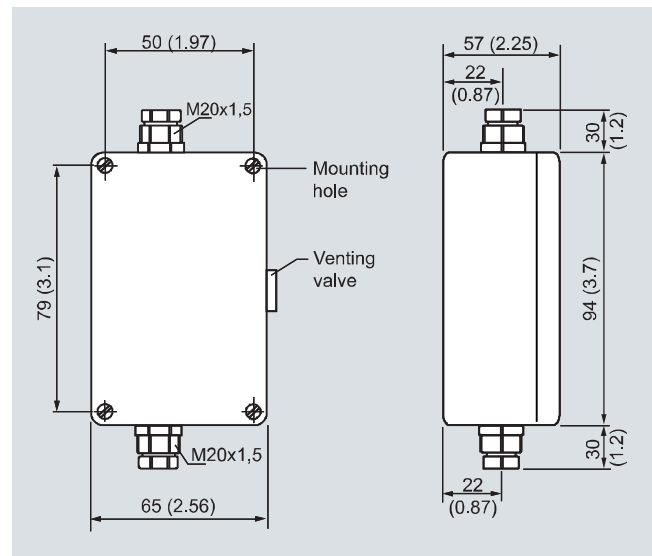

Junction box, dimensions in mm (inch)

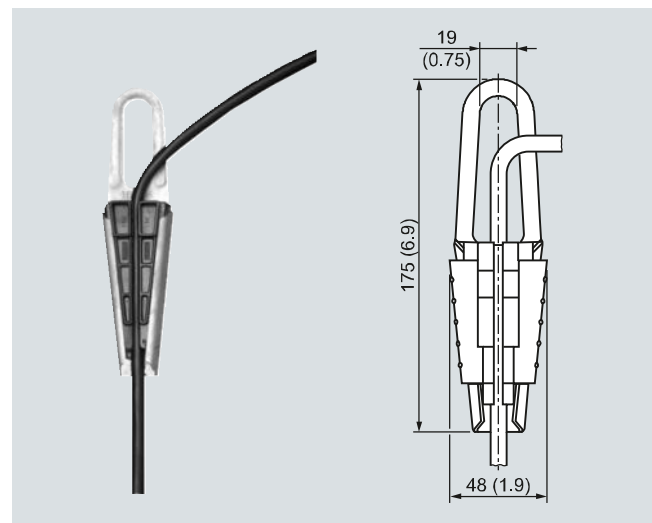

Cable hanger, dimensions in mm (inch)

Pressure Measurement

Transmitters for basic requirements

SITRANS P MPS (submersible sensor)
Transmitter for hydrostatic level

1

More information

Determination of the measuring range in case of media with a density $\neq 1000 \text{ kg/m}^3$ (medium \neq water)

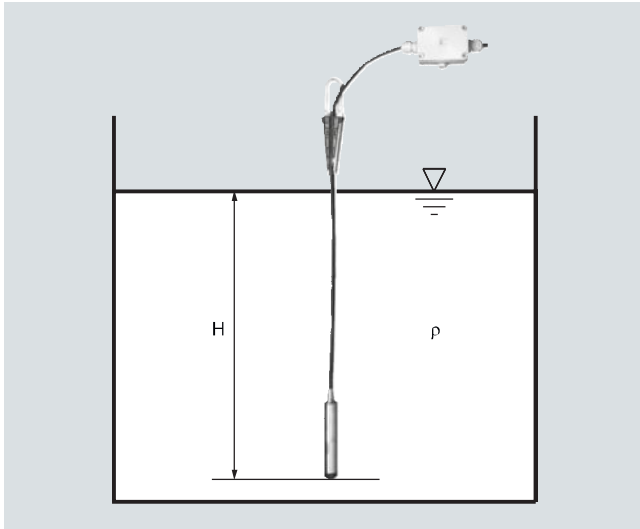

Calculation of the measuring range:

$$p = \rho \times g \times H$$

with:

ρ = density of medium

g = local acceleration due to gravity

H = maximum level

Example:

Medium: Diesel fuel, $\rho = 850 \text{ kg/m}^3$

Acceleration due to gravity: 9.81 m/s^2

Start-of-scale: 0 m

Maximum level: 6.2 m

Cable length: 7 m, FEP cable

Calculation:

$$p = 850 \text{ kg/m}^3 \times 9.81 \text{ m/s}^2 \times 6.2 \text{ m}$$

$$p = 51698.7 \text{ N/m}^2$$

$$p = 517 \text{ mbar}$$

Transmitter to be ordered:

7MF1570-9AA02-Z, H5C + Y01

Y01: 0 ... 517 mbar