

# Rosemount 8800D Series Vortex Flowmeter



## Hart® and FOUNDATION™ fieldbus Protocols

- All welded, non-clog design provides maximum performance, reliability and enhanced safety by eliminating ports and gaskets. No seals, just steel.
- CriticalProcess™ Vortex eliminates bypass piping and optimizes safety during sensor health verification.
- Available with optional MultiVariable™ output. Internal temperature compensation provides cost-effective saturated steam mass flow measurement.
- Adaptive Digital Signal Processing (ADSP) provides vibration immunity and flow range optimization.
- Reducer™ Vortex extends the measurable flow range, reduces installation costs, and minimizes project risk.
- Simplified troubleshooting through device diagnostics and meter verification.
- Available in wafer, flanged, dual, reducer and high pressure designs.



## The Rosemount 8800D delivers reliability and maximum process availability

- Rosemount Reliability - The 8800D Vortex eliminates impulse lines, ports, and gaskets to improve reliability.
- Non-clog Design - Unique all welded, gasket-free construction which has no ports or crevices that can clog.
- Vibration Immunity - Mass balancing of the sensor system, and Adaptive Digital Signal Processing (ADSP) provide vibration immunity.
- Replaceable Sensor - The sensor is isolated from the process and can be replaced without breaking the process seal. All line sizes use the same sensor design allowing a single spare to serve every meter.
- Simplified Troubleshooting - Device Diagnostics enable field verification of meter electronics and sensor without process shutdown.



## The Rosemount 8800D Offering

- The 8800D is available in wafer style meter bodies for 1/2 through 8-in. line sizes, and ASME B16.5, EN 1092-1, or JIS B2220 flanged style meter bodies for 1/2 through 12-in. line sizes.
- Alignment rings, provided with each wafer-style flowmeter,<sup>27</sup> ensure that the meter body is properly centered with the adjacent piping.
- The wafer, flanged, and weld end style meter bodies are available in 316 stainless steel and nickel alloy materials of construction.
- Available up to ASME B16.5 class 1500 for 1 through 8-in. (25 mm through 200 mm) line sizes.

Available with FOUNDATION fieldbus functionality which includes Device Diagnostics and PlantWeb Alerts.



## Contents

Ordering Information ..... 7

Specifications ..... 12

Typical Flow Ranges ..... 17

Product Certifications ..... 27

Dimensional Drawings ..... 32

## 8800D Critical Process™ Vortex Increases Process Availability and Enhances Overall Safety

- Eliminate bypass piping for critical process installations  
Traditional vortex installations in critical applications include a bypass line to allow process fluid to be re-directed around the vortex flow meter during routine sensor maintenance. Rosemount's unique non-wetted sensor can be installed without bypass piping, even in the most difficult process environments.
- Improve process availability  
Eliminate the need to shut down the process during routine maintenance and meter verification.
- Enhances safety in hazardous process fluid applications  
A needle valve enables access to the sensor cavity to verify that no process fluid is present.
- Available in Flanged, Reducer, and Dual Vortex meter designs in 1 through 12 inch meter body sizes for ASME B16.5 flange connections. Available in 40 through 300 mm meter body sizes for EN 1092-1 and JIS B2220 flange connections.



## The 8800DD Dual Sensor Vortex Provides Enhanced Safety

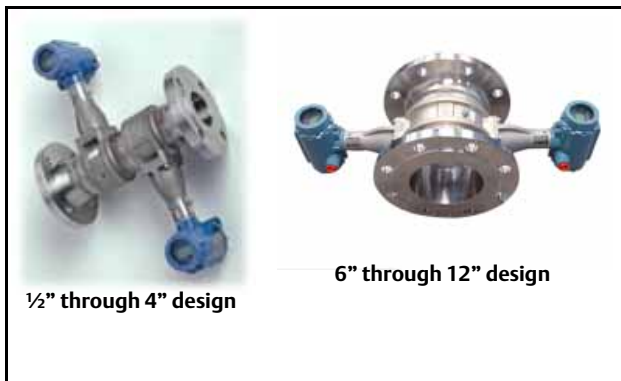

- Safety Integrated Systems (SIS) - Ideal solution where redundant flow signals are required.
- Rosemount Reliability - Designed with same electronics, sensor, and meter body as the 8800D.
- Redundant Flow Measurement - The Dual Vortex meter is constructed of two complete vortex meters: sensor, electronics, and shedder bar. The 6- through 12-inch design leverages a single shedder bar for both sensors, maintaining redundancy while reducing the lay-length of the flowmeter body. The meters are flow calibrated to provide an accurate single flowmeter with two independent flow measurements.
- Available as flanged meter for 1/2 through 12-in. stainless steel and nickel alloy materials of construction.

## 8800D Multivariable vortex reduces installation costs, simplifies installation, and improves performance in saturated steam



- **MultiVariable Vortex Design**  
Incorporates temperature sensor into the vortex meter using the shedder bar as a thermowell, which keeps the vortex and temperature sensors isolated from process for easy verification and replacement.
- **Increased performance in Saturated Steam**  
Performance in saturated steam is improved due to the fact that the electronics will be compensating for changes in the process temperature.
- **Temperature Compensated Capability for Saturated Steam**  
Calculates density from measured process temperature and uses the calculated density to provide a temperature compensated mass flow.
- **Reduces Installed Costs**  
MultiVariable Vortex eliminates the need for an external thermowell and temperature sensor.
- **Available with Flanged and Reducer™ Vortex in 1 1/2 through 12 inch meter body sizes**

- **Available with Flow Computer for Additional Functionality**  
Integrate the MultiVariable Vortex with a pressure transmitter for full pressure and temperature compensation of superheated steam and various gases and provides the following additional functionality:

- Remote Communications
- Heat Flow Calculations
- Remote Totalization
- Peak Demand Calculation
- Data Logging Capabilities



Please see Product Data Sheet 00813-0100-4005 for more information on the Rosemount Flow Computer.

## The Rosemount 8800DR Reducer Vortex Extends the Measurable Flow Range at A reduced Cost



- Rosemount Reliability - Designed with same electronics, sensor, and meter body as the 8800D.
- Reduced Cost - Eliminates field assembly and welding of separate reducers and piping reducing installed cost by as much as 50%.
- Extended Measurable Flow - Low-end flow range is doubled with the Rosemount 8800DR Reducer Vortex.
- Reduced Project Risk - Reducer Vortex and the Standard Vortex have the same face-to-face dimension. As a result either meter can be used without affecting pipe layout.
- Available as flanged meter for 1 through 14-in. stainless steel and nickel alloy materials of construction.
- Available with FOUNDATION fieldbus functionality.

## Rosemount 8800D Vortex Flowmeter with FOUNDATION fieldbus

The software for the 8800D Flowmeter with FOUNDATION fieldbus permits remote testing and configuration using any FOUNDATION fieldbus-compliant host, such as the DeltaV system from Emerson Process Management.

### Transducer Block

The transducer block calculates flow from sensor frequency. The calculation includes information about damping, shedding frequency, K-factor, process fluid, pipe ID, and diagnostics.

### Resource Block

The resource block contains physical transmitter information, including available memory, manufacturer identification, device type, software tag, and unique identification.

### Backup Link Active Scheduler (LAS)

The transmitter is classified as a device link master. A device link master can function as a Link Active Scheduler (LAS) if the current link master device fails or is removed from the segment.

The host or other configuration tool is used to download the schedule for the application to the link master device. In the absence of a primary link master, the transmitter will claim the LAS and provide permanent control for the H1 segment.

### Diagnostics

The transmitter automatically performs continuous self-diagnostics. The user can perform on-line testing of the transmitter digital signal. Advanced simulation diagnostics are available. This enables remote verification of the electronics via a flow signal generator built into the electronics. The sensor strength value can be used to view the process flow signal and provide information regarding filter settings.

### FOUNDATION Fieldbus Function Blocks

#### Analog Input

The AI function block processes the measurement and makes it available to other function blocks. The AI function block also allows filtering, alarming, and engineering unit changes.

The 8800D Flowmeter with FOUNDATION fieldbus comes with five AI function blocks. Two of the AI function blocks, flow and signal strength, come as standard. Three additional AI function blocks are available when the MTA option is selected: electronics temperature, process temperature, and process density. Note that process density is only available when the process fluid is configured as temperature compensated saturated steam, shown as TComp Sat Steam in the device.

#### Proportional/Integral/Derivative

The optional PID function block provides a sophisticated implementation of the universal PID algorithm. The PID function block features input for feed forward control, alarms on the process variable, and control deviation. The PID type (series or Instrument Society of America [ISA]) is user-selectable on the derivative filter.

#### Integrator

The standard integrator block is available for totalization of flow.

#### Arithmetic

The standard arithmetic block is available for various computations.

#### Setup

Basic setup requires connecting the transmitter to a fieldbus network or Field Communicator. The FOUNDATION fieldbus-compliant host will automatically establish communication with the device.

The Rosemount 8800D Flowmeter can be easily configured using the DeltaV system. User-configurable parameters include: tag, scaling and units, process fluid type, damping, fixed process density, pipe inside diameter (ID)<sup>(1)</sup>, and fixed process temperature<sup>(1)</sup>.

Tagging information can be entered into the transmitter to allow identification and a physical description. 32-character tags are provided for identification of the transmitter and each function block.

(1) Process temperature and pipe ID have known effects on the K-factor. The 8800D software automatically accounts for these effects by compensating the K-factor.

## Ordering Information

**Table 1. Rosemount 8800D Vortex Flowmeter**

★ The Standard offering represents the most common options. The starred options (★) should be selected for best delivery.

The Expanded offering is subject to additional delivery lead time.

Model	Product Description	
8800D	Vortex Flowmeter	
<b>Meter Style</b>		
<b>Standard</b>		<b>Standard</b>
F	Flanged style	★
W	Wafer style	★
R	Reducer Style (Flanged style only)	★
<b>Expanded</b>		
D	Dual-sensor style (Flanged style only)	
<b>Line Size</b>		
<b>Standard</b>		<b>Standard</b>
005	1/2-in. (15 mm) (Not available for Rosemount 8800DR)	★
010	1-in. (25 mm)	★
015	1 1/2-in. (40 mm)	★
020	2-in. (50 mm)	★
030	3-in. (80 mm)	★
040	4-in. (100 mm)	★
060	6-in. (150 mm)	★
080	8-in. (200 mm)	★
<b>Expanded</b>		
100	10-in. (250mm)	
120	12-in. (300mm)	
<b>Wetted Materials</b>		
<b>Standard</b>		<b>Standard</b>
S	316 wrought stainless and CF-3M cast stainless Note: Material of construction is 316/316L	★
<b>Expanded</b>		
H	UNS N06022 wrought Nickel Alloy; CW2M cast Nickel Alloy Note: See <a href="#">Table 2</a>	
	Other wetted materials are available. Consult factory for details.	
<b>Flange or Alignment Ring Size</b>		
<b>Standard</b>		<b>Standard</b>
A1	ASME B16.5 (ANSI) RF Class 150	★
A3	ASME B16.5 (ANSI) RF Class 300	★
K1	EN 1092-1 PN 16 (PN 10/16 for wafer style) Type B1	★
K3	EN 1092-1 PN 40 (PN 25/40 for wafer style) Type B1	★
<b>Expanded</b>		
A6	ASME B16.5 (ANSI) RF Class 600	
A7 <sup>(1)</sup>	ASME B16.5 (ANSI) RF Class 900	
A8 <sup>(2)</sup>	ASME B16.5 (ANSI) RF Class 1500	
B1 <sup>(3)</sup>	ASME B16.5 (ANSI) RTJ Class 150 for flange-style only	
B3	ASME B16.5 (ANSI) RTJ Class 300 for flange-style only	
B6	ASME B16.5 (ANSI) RTJ Class 600 for flange-style only	
B7 <sup>(1)</sup>	ASME B16.5 (ANSI) RTJ Class 900 for flange-style only	
B8 <sup>(2)</sup>	ASME B16.5 (ANSI) RTJ Class 1500 for flange-style only	
C1	ASME B16.5 (ANSI) RF Class 150, smooth finish	
C3	ASME B16.5 (ANSI) RF Class 300, smooth finish	
C6	ASME B16.5 (ANSI) RF Class 600, smooth finish	



**Table 1. Rosemount 8800D Vortex Flowmeter**

★ The Standard offering represents the most common options. The starred options (★) should be selected for best delivery.

The Expanded offering is subject to additional delivery lead time.

<b>Expanded</b>		
C7 <sup>(1)</sup>	ASME B16.5 (ANSI) RF Class 900, smooth finish	
C8 <sup>(2)</sup>	ASME B16.5 (ANSI) RF Class 1500, smooth finish	
K0	EN 1092-1 PN 10 Type B1	
K2	EN 1092-1 PN 25 Type B1	
K4	EN 1092-1 PN 63 Type B1	
K6	EN 1092-1 PN 100 Type B1	
K7 <sup>(1)</sup>	EN 1092-1 PN 160 Type B1	
L0	EN 1092-1 PN 10 Type B2	
L1	EN 1092-1 PN 16 (PN 10/16 for wafer style) Type B2	
L2	EN 1092-1 PN 25 Type B2	
L3	EN 1092-1 PN 40 (PN 25/40 for wafer style) Type B2	
L4	EN 1092-1 PN 63 Type B2	
L6	EN 1092-1 PN 100 Type B2	
L7 <sup>(1)</sup>	EN 1092-1 PN 160 Type B2	
M0	EN 1092-1 PN 10 Type D for flange style only	
M1	EN 1092-1 PN 16 Type D for flange style only	
M2	EN 1092-1 PN 25 Type D for flange style only	
M3	EN 1092-1 PN 40 Type D for flange style only	
M4	EN 1092-1 PN 63 Type D for flange style only	
M6	EN 1092-1 PN 100 Type D for flange style only	
M7 <sup>(1)</sup>	EN 1092-1 PN 160 Type D for flange style only	
J1	JIS 10K	
J2	JIS 20K	
J4	JIS 40K	
W1 <sup>(4)</sup>	Weld End, Schedule 10S	
W4 <sup>(4)</sup>	Weld End, Schedule 40S	
W8 <sup>(4)</sup>	Weld End, Schedule 80S	
W9 <sup>(3)(4)</sup>	Weld End, Schedule 160S	
<b>Sensor Process Temperature Range</b>		
<b>Standard</b>		<b>Standard</b>
N	Standard: -40 to 450°F (-40 to 232°C)	★
E	Extended: -330 to 800°F (-200 to 427°C)	★
<b>Expanded</b>		
S	Severe Service: -330 to 800 °F (-200 to 427 °C)	
<b>Conduit Entry</b>		
<b>Standard</b>		<b>Standard</b>
1	1/2 -14 NPT – Aluminum Housing	★
2	M20 × 1.5 – Aluminum Housing	★
4	G <sup>1</sup> / <sub>2</sub> (One Conduit Entry) – Aluminum Housing	★
5	G <sup>1</sup> / <sub>2</sub> (Two Conduit Entries) – Aluminum Housing	★
<b>Expanded</b>		
6 <sup>(5)</sup>	1/2 - 14 NPT - SST Housing	
7 <sup>(5)</sup>	M20 x 1.5 - SST Housing	
<b>Outputs</b>		
<b>Standard</b>		<b>Standard</b>
D	4-20 mA digital electronics (HART protocol)	★
P	4-20 mA digital electronics (HART protocol) with scaled pulse	★
F	FOUNDATION fieldbus digital signal	★



**Table 1. Rosemount 8800D Vortex Flowmeter**

★ The Standard offering represents the most common options. The starred options (★) should be selected for best delivery.

The Expanded offering is subject to additional delivery lead time.

Calibration		
<b>Standard</b>		<b>Standard</b>
1	Flow calibration	★
<b>Options</b>		
<b>MultiVariable Options</b>		
<b>Expanded</b>		
MTA <sup>(6)</sup>	MultiVariable output with Integral Temperature Sensor	
<b>Hazardous Locations Certifications</b>		
<b>Standard</b>		<b>Standard</b>
E5	FM Explosion-proof; Dust Ignition-proof	★
I5	FM Intrinsically Safe; Non-incendive	★
IE <sup>(7)</sup>	FM FISCO Intrinsically Safe	★
K5	FM Explosion-proof; Intrinsically Safe; Non-incendive; Dust Ignition-proof	★
E6	CSA Explosion-proof; Division 2 Dust Ignition-proof	★
I6	CSA Intrinsically Safe	★
IF <sup>(7)</sup>	CSA FISCO Intrinsically Safe	★
K6	CSA Explosion-proof; Intrinsically Safe; Division 2; Dust-Ignition-proof	★
KB	FM and CSA Explosion-proof, Dust Ignition-proof, Intrinsically Safe, Non-incendive	★
E1	ATEX Flameproof	★
I1	ATEX Intrinsic Safety ia; Intrinsic Safety ic	★
IA <sup>(7)</sup>	ATEX FISCO Intrinsic Safety	★
N1	ATEX Type n	★
ND	ATEX Dust	★
K1	ATEX Flameproof; Intrinsic Safety; Type n; Dust	★
E7	IECEX Flameproof	★
I7	IECEX Intrinsic Safety	★
IG <sup>(7)</sup>	IECEX FISCO Intrinsic Safety	★
N7	IECEX Type n	★
K7	IECEX Flameproof; Intrinsic Safety; Type n; Dust	★
E2	INMETRO Flameproof	★
I2	INMETRO Intrinsic Safety	★
E3	China Flameproof; Dust	★
I3	China Intrinsic Safety	★
N3	China Type n	★
IH <sup>(7)</sup>	China FISCO/FNICO Intrinsic Safety	★
K3	China Flameproof; Dust; Intrinsic Safety; Type n	★
E4 <sup>(8)</sup>	TIIS Flameproof	★
IB <sup>(7)</sup>	INMETRO FISCO Intrinsic Safety	★
<b>Plantweb Control Functionality</b>		
<b>Standard</b>		<b>Standard</b>
A01 <sup>(9)</sup>	Basic Control: One Proportional/Integral/Derivative (PID) Function Block	★
<b>Conduit Electrical Connector</b>		
<b>Expanded</b>		
GE <sup>(10)</sup>	M12, 4-pin, Male Connector (eurofast <sup>®</sup> )	
GM <sup>(10)</sup>	A size Mini, 4-pin, Male Connector (minifast <sup>®</sup> )	
GN	ATEX Flameproof A size, Mini 4-pin male connector (minifast)	

**Table 1. Rosemount 8800D Vortex Flowmeter**

★ The Standard offering represents the most common options. The starred options (★) should be selected for best delivery. The Expanded offering is subject to additional delivery lead time.

Other Options		
<b>Standard</b>		<b>Standard</b>
C4 <sup>(11)</sup>	NAMUR alarm and saturation values, high alarm	★
CN <sup>(11)</sup>	NAMUR alarm and saturation values, low alarm	★
V5	External ground screw assembly	★
T1	Transient protection terminal block	★
P2	Cleaning for special services	★
PD	Pressure Equipment Directive (PED, per 97/23/EC)	★
M5	LCD indicator	★
R10	Remote electronics with 10 ft (3,0 m) cable	★
R20	Remote electronics with 20 ft (6,1 m) cable	★
R30	Remote electronics with 30 ft (9,1 m) cable	★
R33	Remote electronics with 33 ft. (10 m) cable	★
R50	Remote electronics with 50 ft (15.,2 m) cable	★
<b>Expanded</b>		
RXX <sup>(12)</sup>	Remote electronics with customer-specified cable length (up to 75 ft (23 m) maximum)	
CPA <sup>(13)</sup>	CriticalProcess Online Sensor	
<b>Certification Options</b>		
<b>Standard</b>		<b>Standard</b>
Q4	Calibration data sheet per ISO 10474 3.1B and EN 10204 3.1	★
Q8	Material traceability certification per ISO 10474 3.1B and EN 10204 3.1	★
QP	Calibration certification and tamper evident seal	★
Q25	NACE MR0103 Certificate of Compliance	★
Q66	Certificate for Procedure Qualification Records	★
Q67	Certificate for Welder Performance Qualification Records	★
Q68	Certification for Welding Procedure Specifications	★
Q69 <sup>(14)</sup>	Inspection certificate weld examination (wafer) per ISO 10474 3.1B and EN 10204 3.1	★
Q76	Certification of Positive Material Identification	★
Q79	Certification for Combo PQR/WPQ/WPS	★
<b>Expanded</b>		
Q70	Inspection certificate weld examination (flanged) per ISO 10474 3.1B and EN 10204 3.1	
Q71	Inspection certification weld examination (flanged) per ISO 10474 3.1B (includes x-rays) and EN 10204 3.1	
QKH	KHK Documentation Package	
SLL	Lloyd's Register (LR) Type Approval	
<b>Quick Installation Guide (QIG) Language Options (Default is English)</b>		
<b>Standard</b>		<b>Standard</b>
YA	Danish QIG	★
YB	Hungarian QIG	★
YC	Czech QIG	★
YD	Dutch QIG	★
YF	French QIG	★
YG	German QIG	★
YH	Finnish QIG	★
YI	Italian QIG	★
YJ	Japanese QIG	★
YM	Chinese (Mandarin) QIG	★
YN	Norwegian QIG	★
YL	Polish QIG	★
YP	Portuguese QIG	★
YR	Russian QIG	★
YS	Spanish QIG	★
YW	Swedish QIG	★
<b>Typical Model Number: 8800D F 020 S A1 N 1 D 1 M5</b>		

- (1) Available on flanged and dual style meters from 1/2" - 8" (15-200 mm) and Reducer style meters from 1" - 8" (25 - 200 mm).
- (2) Only available for flange and dual style meters from 1" - 8" (25-200 mm).
- (3) Not available with 1/2-in. line size.
- (4) W1, W4, W8, and W9 are only available with Meter Style F.
- (5) No TIIS approval
- (6) Available with Rosemount 8800DF from 1 1/2-in (40 mm) through 12-in. (300 mm). Available with 8800DR from 2-in (50 mm) through 12-in (300 mm). Not available with 8800DW or 8800DD.
- (7) Fieldbus Intrinsic Safe Concept (FISCO) available with output code F (FOUNDATION Fieldbus digital signal) only.
- (8) TIIS Flameproof Approval requires G1/2 conduit entry.
- (9) Requires output code F.
- (10) Not available with certain hazardous location certifications. Contact a Rosemount representative for details.
- (11) NAMUR compliant operation and the alarm latch options are pre-set at the factory and can be changed to standard operation in the field.
- (12) XX is a customer specified length in feet.
- (13) The CPA option is not available on wafer, 1/2-in. flange, or 1-in. reducer units. In addition it is not available on 1" flanged and 1.5" reducer JIS 10K, EN PN40, or EN PN16.
- (14) Q69 available for all Nickel Alloy wafers and stainless steel wafers in line sizes 1/2-in. (15 mm), 6-in. (150 mm), and 8-in. (200 mm).

**Table 2. Method of Construction for the 8800DF/8800DD in Nickel Alloy.**

Line Size	A1	A3	A6	A7	K1	K3	K4	K6	K7
1/2 (15)	C	C	C	W	W	W	NA	W	W
1 (25)	C	C	C	W	W	W	NA	W	W
1 1/2 (40)	C	C	C	W	W	W	NA	W	W
2 (50)	C	C	C	W	C	C	W	W	W
3 (80)	C	C	C	W	C	C	W	W	W
4 (100)	C	C	C	W	C	C	W	W	W
6 (150)	C	C	C	CF	W	W	W	W	CF
8 (200)	C	C	C	CF	W	W	W	W	CF
10 (250)	W	W	W	NA	W	W	W	W	NA
12 (300)	W	W	W	NA	W	W	W	W	NA
C = Nickel Alloy collar and 316 SST lap flange. If weld neck flange is required, V0022 can be ordered.									
W = Nickel Alloy weld neck flange.									
CF = Consult Factory									
NA = Not Available									
All 8800DR Reducer Vortex Meters with Nickel Alloy materials of construction use weld neck flanges.									
Flange codes other than those listed in <a href="#">Table 2</a> all use weld neck flanges.									

# Specifications

## Functional Specifications

### Process Fluids

Liquid, gas, and steam applications. Fluids must be homogeneous and single-phase.

### Line Sizes

#### Wafer

1/2, 1, 1 1/2, 2, 3, 4, 6, and 8 inches  
(DN 15, 25, 40, 50, 80, 100, 150, and 200)

#### Flanged and Dual-Sensor Style

1/2, 1, 1 1/2, 2, 3, 4, 6, 8, 10, and 12 inches  
(DN 15, 25, 40, 50, 80, 100, 150, 200, 250, and 300)

#### Reducer

1, 1 1/2, 2, 3, 4, 6, 8, 10, and 12 inches  
(DN 25, 40, 50, 80, 100, 150, 200, 250, and 300)

### Pipe Schedules

Process piping Schedules 10, 40, 80, and 160.

#### NOTE

The appropriate bore diameter of the process piping must be entered using the Field Communicator or AMS Device Manager. Meters will be shipped from the factory at the Schedule 40 default value unless otherwise specified.

### Measurable Flow Rates

Capable of processing signals from flow applications which meet the sizing requirements below.

To determine the appropriate flowmeter size for an application, process conditions must be within the Reynolds number and velocity limitations for the desired line size provided in [Table 3](#), [Table 4](#), and [Table 5](#).

#### NOTE

Consult your local sales representative to obtain a computer sizing program that describes in greater detail how to specify the correct flowmeter size for an application.

The Reynolds number equation shown below combines the effects of density ( $\rho$ ), viscosity ( $\mu_{cp}$ ), pipe inside diameter ( $D$ ), and flow velocity ( $V$ ).

$$R_D = \frac{VD\rho}{\mu_{cp}}$$

**Table 3. Minimum Measurable Meter Reynolds Numbers**

Meter Sizes (Inches / DN)	Reynolds Number Limitations
1/2 through 4/15 through 100	5000 minimum
6 through 12/150 through 300	

**Table 4. Minimum Measurable Meter Velocities<sup>(1)</sup>**

	Feet per Second	Meters per Second
Liquids <sup>(2)</sup>	$\sqrt{36/\rho}$	$\sqrt{54/\rho}$
Gases <sup>(2)</sup>	$\sqrt{36/\rho}$	$\sqrt{54/\rho}$

**The  $\rho$  is the process fluid density at flowing conditions in lb/ft<sup>3</sup> for ft/s and kg/m<sup>3</sup> for m/s**

(1) Velocities are referenced to schedule 40 pipe.

(2) This minimum measurable meter velocity is based on default filter settings.

**Table 5. Maximum Measurable Meter Velocities<sup>(1)</sup>  
(Use the smaller of the two values)**

	Feet per Second	Meters per Second
Liquids	$\sqrt{90,000/\rho}$ or 25	$\sqrt{134,000/\rho}$ or 7.6
Gases <sup>(2)</sup>	$\sqrt{90,000/\rho}$ or 300	$\sqrt{134,000/\rho}$ or 91.4

**The  $\rho$  is the process fluid density at flowing conditions in lb/ft<sup>3</sup> for ft/s and kg/m<sup>3</sup> for m/s**

(1) Velocities are referenced to schedule 40 pipe.

(2) Accuracy limitations for gas and steam for Dual-style meters (1/2-in. to 4-in.): max velocity of 100 ft/s (30.5 m/s).

**Process Temperature Limits****Standard**

-40 to 450 °F (-40 to 232 °C)

**Extended**

-330 to 800 °F (-200 to 427 °C)

- - 157 °F to 800 °F (-105 to 427 °C) for European Pressure Equipment Directive (PED), consult factory for lower temperature requirements.

**MultiVariable (MTA option)**

-40 to 800 °F (-40 to 427 °C)

- Use above 450 °F (232 °C) requires Extended Sensor

**Output Signals****4–20 mA Digital HART Signal**

Superimposed on 4–20 mA signal

**Optional Scalable Pulse Output**

0 to 10000 Hz; transistor switch closure with adjustable scaling via HART communications; capable of switching up to 30 Vdc, 120 mA maximum

**Digital FOUNDATION fieldbus signal**

Completely digital output with FOUNDATION fieldbus communication (ITK 5.2 compliant).

**Analog Output Adjustment**

Engineering units and lower and upper range values are user-selected. Output is automatically scaled to provide 4 mA at the selected lower range value, 20 mA at the selected upper range value. No frequency input is required to adjust the range values.

**Scalable Frequency Adjustment**

The scalable pulse output can be set to a specific velocity, volume, or mass (i.e. 1 pulse = 1 lb). The scalable pulse output can also be scaled to a specific rate of volume, mass, or velocity (i.e. 100 Hz = 500 lb/hr).

**Ambient Temperature Limits****Operating**

-58 to 185 °F (-50 to 85 °C)

-4 to 185 °F (-20 to 85 °C) for flowmeters with local indicator

**Storage**

-58 to 185 °F (-50 to 85 °C)

-50 to 185 °F (-46 to 85 °C) for flowmeters with local indicator

**Pressure Limits****Flange Style Meter**

Rated for ASME B16.5 Class 150, 300, 600, 900, and 1500, EN 1092-1 PN 10, 16, 25, 40, 63, 100, and 160, and JIS 10K, 20K, and 40K

**Reducer Style Meter**

Rated for ASME B16.5 Class 150, 300, 600, and 900, EN 1092-1 PN 10, 16, 25, 40, 63, 100, and 160.

**Dual Sensor Style Meter**

Rated for ASME B16.5 Class 150, 300, 600, 900, and 1500, EN 1092-1 PN 10, 16, 25, 40, 63, 100, and 160, and JIS 10K, 20K, and 40K

**Wafer Style Meter**

Rated for ASME B16.5 Class 150, 300, and 600, EN 1092-1 PN 10, 16, 25, 40, 63, and 100, and JIS 10K, 20K, and 40K

**NOTE**

All Wafer Style Meters are pressure rated and labeled at 1500 PSI / 10.34 MPa at 100 °F / 38 °C regardless of Alignment Ring Size code ordered.

**Weld-End Style Meter**

W1 Welds to Schedule 10 mating pipe

1-4 inch line size 720 psig (4.96 MPa-g)

6-12 inch line size 275 psig (1.92 MPa-g)

W4 Welds to Schedule 40 mating pipe

1-4 inch line size 1440 psig (9.93 MPa-g)

6-12 inch line size 720 psig (4.96 MPa-g)

W8 Welds to Schedule 80 mating pipe

1-4 inch line size 2160 psig (14.9 MPa-g)

6-12 inch line size 1440 psig (9.93 MPa-g)

W9 Welds to Schedule 160 mating pipe

1-4 inch line size 3600 psig (24.8 MPa-g)

6-12 inch line size 2160 psig (14.9 MPa-g)

**NOTE**

1-in. (25 mm), and 1.5-in. (40 mm) weld to Schedule 80 mating pipe

**Power Supply**

**HART Analog**

External power supply required. Flowmeter operates on 10.8 to 42 Vdc terminal voltage (with 250-ohm minimum load required for HART communications, 16.8 Vdc power supply is required)

**FOUNDATION fieldbus**

External power supply required. Flowmeter operates on 9 to 32 Vdc, 18 mA maximum.

**Power Consumption**

One watt maximum

**Load Limitations (HART Analog)**

Maximum loop resistance is determined by the voltage level of the external power supply, as described by:

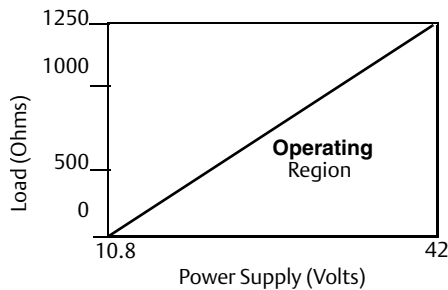

$$R_{max} = 41.7(V_{ps} - 10.8)$$

$V_{ps}$  = Power Supply Voltage (Volts)  
 $R_{max}$  = Maximum Loop Resistance (Ohms)

**Note**

HART Communication requires a minimum loop resistance of 250 ohms.

**Optional LCD Indicator**

The optional LCD indicator is capable of displaying:

HART	FOUNDATION Fieldbus
Primary Variable	Primary Variable
Velocity Flow	Percent of Range
Volumetric Flow	Shedding Frequency
Mass Flow	Electronics Temperature (MTA only)
Percent of Range	Process Temperature (MTA only)
Analog Output	Calculated Process Density (MTA only)
Totalizer	Integrator Output
Shedding Frequency	Totalizer
Pulse Output Frequency	
Electronics Temperature	
Process Temperature (MTA only)	
Calculated Process Density (MTA only)	

If more than one item is selected, the display will scroll through all items selected.

**Enclosure Rating**

FM Type 4X; CSA Type 4X; IP66

**Permanent Pressure Loss**

The approximate permanent pressure loss (PPL) from the Rosemount 8800D flowmeter is calculated for each application in the Vortex sizing software available from your local Rosemount representative. The PPL is determined using the equation:

$$PPL = \frac{A \times \rho_f \times Q^2}{D^4}$$

where:

PPL = Permanent Pressure loss (psi or kPa)

Where:

$\rho_f$  = Density at operating conditions (lb/ft<sup>3</sup> or kg/m<sup>3</sup>)

Q = Actual volumetric flow rate (Gas = ft<sup>3</sup>/min or m<sup>3</sup>/hr; Liquid = gal/min or l/min)

D = Flowmeter bore diameter (in. or mm)

A = Constant depending on meter style, fluid type and flow units. Determined per following table:

**Table 6. Determining the PPL**

Meter Style	English Units		SI Units	
	A <sub>Liquid</sub>	A <sub>Gas</sub>	A <sub>Liquid</sub>	A <sub>Gas</sub>
8800DF/W	3.4 × 10 <sup>-5</sup>	1.9 × 10 <sup>-3</sup>	0.425	118
8800DR	3.91 × 10 <sup>-5</sup>	2.19 × 10 <sup>-3</sup>	0.489	136
8800DD <sup>(1)</sup>	6.12 × 10 <sup>-5</sup>	3.42 × 10 <sup>-3</sup>	0.765	212

(1) For all 6-in. thru 12-in. line sizes A is the same for 8800DD and 8800DF

**Minimum Downstream Pressure (Liquids)**

Flow metering conditions that would allow cavitation, the release of vapor from a liquid, should be avoided. This flow condition can be avoided by remaining within the proper flow range of the meter and by following appropriate system design.

For some liquid applications, incorporation of a back pressure valve should be considered. To prevent cavitation, the minimum downstream pressure should be:

$$P = 2.9 \cdot \Delta P + 1.3 \cdot p_v \text{ or } P = 2.9 \cdot \Delta P + p_v + 0.5 \text{ psia (3.45 kPa)}$$

(use the smaller of the two results)

P = Line pressure five pipe diameters downstream of the meter (psia or kPa abs)

$\Delta P$  = Pressure loss across the meter (psi or kPa)

$p_v$  = Liquid vapor pressure at operating conditions (psia or kPa abs)

**Failure Mode Alarm**

**HART Analog**

If self-diagnostics detect a gross flowmeter failure, the analog signal will be driven to the values below:

Low	3.75
High	21.75
NAMUR Low	3.60
NAMUR High	22.6

High or low alarm signal is user-selectable through the fail mode alarm jumper on the electronics. NAMUR-compliant alarm limits are available through the C4 or CN Option. Alarm type is field configurable also.

**FOUNDATION fieldbus**

The AI block allows the user to configure the alarm to HI-HI, HI, LO, or LO-LO with a variety of priority levels.

**Saturation Output Values**

When the operating flow is outside the range points, the analog output continues to track the operating flow until reaching the saturation value listed below; the output does not exceed the listed saturation value regardless of the operating flow. The NAMUR-Compliant Saturation Values are available through the C4 or CN option. Saturation type is field configurable.

Low	3.9
High	20.8
NAMUR Low	3.8
NAMUR High	20.5

**Damping**

Flow Damping adjustable between 0.2 and 255 seconds.

Process Temperature Damping adjustable between 0.4 and 32.0 seconds (MTA Option Only).

**Response Time**

Three vortex shedding cycles or 300 ms, whichever is greater, maximum required to reach 63.2% of actual input with the minimum damping (0.2 seconds).

**Turn-on Time**

**HART Analog**

Less than four (4) seconds plus the response time to rated accuracy from power up (less than 7 seconds with the MTA Option).

**FOUNDATION fieldbus**

Performance within specifications no greater than 10.0 seconds after power is applied.

**Transient Protection**

The optional transient terminal block prevents damage to the flowmeter from transients induced by lightning, welding, heavy electrical equipment, or switch gears. The transient protection electronics are located in the terminal block.

The transient terminal block meets the following specifications:

IEEE C62.41 - 2002 Category B

3 kA crest (8 × 20 μs)

6 kV crest (1.2 × 50 μs)

6 kV/0.5 kA (0.5 μs, 100 kHz, ring wave)

**Security Lockout**

When the security lockout jumper is enabled, the electronics will not allow you to modify parameters that affect flowmeter output.

**Output Testing**

**Current Source**

Flowmeter may be commanded to set the current to a specified value between 4 and 20 mA.

**Frequency Source**

Flowmeter may be commanded to set the frequency to a specified value between 0 and 10000 Hz.

**Low Flow Cutoff**

Adjustable over entire flow range. Below selected value, output is driven to 4 mA and zero pulse output frequency.



**Humidity Limits**

Operates in 0–95% relative humidity under noncondensing conditions (tested to IEC 60770, Section 6.2.11).

**Overrange Capability**

**HART Analog**

Analog signal output continues to 105 percent of span, then remains constant with increasing flow. The digital and pulse outputs will continue to indicate flow up to the upper sensor limit of the flowmeter and a maximum pulse output frequency of 10400 Hz.

**FOUNDATION fieldbus**

For liquid process fluid type, the transducer block digital output will continue to a nominal value of 25 ft/s. After that, the status associated with the transducer block output will go to UNCERTAIN. Above a nominal value of 30 ft/s, the status will go to BAD.

For gas/steam service, the transducer block digital output will continue to a nominal value of 220 ft/s for 0.5 and 1.0-in. line sizes and a nominal value of 250 ft/s for 1.5–12-in. line sizes. After that, the status associated with the transducer block output will go to UNCERTAIN. Above a nominal value of 300 ft/s for all line sizes, the status will go to BAD.

**Flow Calibration**

Meter bodies are flow-calibrated and assigned a unique calibration factor (K-factor) at the factory. The calibration factor is entered into the electronics, enabling interchangeability of electronics and/or sensors without calculations or compromise in accuracy of the calibrated meter body.

**Status (FOUNDATION fieldbus only)**

If self-diagnostics detect a transmitter failure, the status of the measurement will inform the control system. Status may also set the PID output to a safe value.

**Schedule Entries (FOUNDATION fieldbus only)**

Six (6)

**Links (FOUNDATION fieldbus only)**

Twelve (12)

**Virtual Communications Relationships (VCRs) (FOUNDATION fieldbus only)**

Maximum VCRs 20  
 Number of Permanent Entries 1

**Table 7. Block Information**

Block	Base Index	Execution Time (Milliseconds)
Resource (RB)	1000	—
Transducer (TB)	1200	—
Analog Input 1 (AI 1)	1400	15
Analog Input 2 (AI 2)	1600	15
Proportional/Integral/Derivative (PID)	1800	20
Integrator (INTEG)	2000	25
Arithmetic (ARITH)	2200	20
Analog Input 3 (AI 3)	2400	15
Analog Input 4 (AI 4)	2600	15
Analog Input 5 (AI 5)	2800	15

## Typical Flow Ranges

Table 8 - Table 14 show typical flow ranges for some common process fluids with default filter settings. Consult your local sales representative to obtain a computer sizing program that describes in greater detail the flow range for an application.

**Table 8. Typical pipe velocity ranges for 8800D and 8800DR<sup>(1)</sup>**

Process Line Size (Inches/ DN)	Vortex Meter <sup>(2)</sup>	Liquid Velocity Ranges		Gas Velocity Ranges	
		(ft/s)	(m/s)	(ft/s)	(m/s)
0.5/ 15	8800DF005	0.70 to 25.0	0.21 to 7.6	6.50 to 250.0	1.98 to 76.2
1/ 25	8800DF010	0.70 to 25.0	0.21 to 7.6	6.50 to 250.0	1.98 to 76.2
	8800DR010	0.25 to 8.8	0.08 to 2.7	2.29 to 87.9	0.70 to 26.8
1.5/ 40	8800DF015	0.70 to 25.0	0.21 to 7.6	6.50 to 250.0	1.98 to 76.2
	8800DR015	0.30 to 10.6	0.09 to 3.2	2.76 to 106.1	0.84 to 32.3
2/ 50	8800DF020	0.70 to 25.0	0.21 to 7.6	6.50 to 250.0	1.98 to 76.2
	8800DR020	0.42 to 15.2	0.13 to 4.6	3.94 to 151.7	1.20 to 46.2
3/ 80	8800DF030	0.70 to 25.0	0.21 to 7.6	6.50 to 250.0	1.98 to 76.2
	8800DR030	0.32 to 11.3	0.10 to 3.5	2.95 to 113.5	0.90 to 34.6
4/ 100	8800DF040	0.70 to 25.0	0.21 to 7.6	6.50 to 250.0	1.98 to 76.2
	8800DR040	0.41 to 14.5	0.12 to 4.4	3.77 to 145.2	1.15 to 44.3
6/ 150	8800DF060	0.70 to 25.0	0.21 to 7.6	6.50 to 250.0	1.98 to 76.2
	8800DR060	0.31 to 11.0	0.09 to 3.4	2.86 to 110.2	0.87 to 33.6
8/ 200	8800DF080	0.70 to 25.0	0.21 to 7.6	6.50 to 250.0	1.98 to 76.2
	8800DR080	0.40 to 14.4	0.12 to 4.4	3.75 to 144.4	1.14 to 44.0
10/ 250	8800DF100	0.90 to 25.0	0.27 to 7.6	6.50 to 250.0	1.98 to 76.2
	8800DR100	0.44 to 15.9	0.13 to 4.8	4.12 to 158.6	1.26 to 48.3
12/ 300	8800DF120	1.10 to 25.0	0.34 to 7.6	6.50 to 250.0	1.98 to 76.2
	8800DR120	0.63 to 17.6	0.19 to 5.4	4.58 to 176.1	1.40 to 53.7

(1) Table 8 is a reference of pipe velocities that can be measured for the standard Rosemount 8800D and the reducer Rosemount 8800DR Vortex Meters. It does not consider density limitations, as described in tables 2 and 3. Velocities are referenced in schedule 40 pipe.

(2) Velocity range of the Rosemount 8800DW is the same as Rosemount 8800DF.

**Table 9. Water Flow Rate Limits for the Rosemount 8800D and 8800DR<sup>(1)</sup>**

Process Line Size (Inches/ DN)	Vortex Meter <sup>(2)</sup>	Minimum and Maximum Measurable Water Flow Rates*	
		Gallons/Minute	Cubic Meters/Hour
0.5/ 15	8800DF005	1.76 to 23.7	0.40 to 5.4
1/ 25	8800DF010	2.96 to 67.3	0.67 to 15.3
	8800DR010	1.76 to 23.7	0.40 to 5.4
1.5/ 40	8800DF015	4.83 to 158	1.10 to 35.9
	8800DR015	2.96 to 67.3	0.67 to 15.3
2/ 50	8800DF020	7.96 to 261	1.81 to 59.4
	8800DR020	4.83 to 158.0	1.10 to 35.9
3/ 80	8800DF030	17.5 to 576	4.00 to 130
	8800DR030	7.96 to 261.0	1.81 to 59.3
4/ 100	8800DF040	30.2 to 992	6.86 to 225
	8800DR040	17.5 to 576	4.00 to 130
6/ 150	8800DF060	68.5 to 2251	15.6 to 511
	8800DR060	30.2 to 992	6.86 to 225
8/ 200	8800DF080	119 to 3898	27.0 to 885
	8800DR080	68.5 to 2251	15.6 to 511
10/ 250	8800DF100	231 to 6144	52.2 to 1395
	8800DR100	119 to 3898	27.0 to 885
12/ 300	8800DF120	391 to 8813	88.8 to 2002
	8800DR120	231 to 6144	52.2 to 1395

\*Conditions: 77 °F (25 °C) and 14.7 psia (1.01 bar absolute)

(1) Table 9 is a reference of flow rates that can be measured for the standard Rosemount 8800D and the reducer 8800DR Vortex Meters. It does not consider density limitations, as described in tables 2 and 3.

(2) Velocity range of the 8800DW is the same as 8800DF.

**Table 10. Air Flow Rate Limits at 59 °F (15 °C)**

Process Pressure	Flow Rate Limits	Minimum and Maximum Air Flow Rates for line sizes 1/2-in./DN 15 through 1-in./DN 25							
		1/2-in./DN 15				1-in./DN 25			
		Rosemount 8800D		Rosemount 8800DR		Rosemount 8800D		Rosemount 8800DR	
		ACFM	ACMH	ACFM	ACMH	ACFM	ACMH	ACFM	ACMH
0 psig (0 bar G)	max	27.9	47.3	Not Available	Not Available	79.2	134	27.9	47.3
	min	4.62	7.84	Available	Available	9.71	16.5	4.62	7.84
50 psig (3,45 bar G)	max	27.9	47.3	Not Available	Not Available	79.2	134	27.9	47.3
	min	1.31	2.22	Available	Available	3.72	6.32	1.31	2.22
100 psig (6,89 bar G)	max	27.9	47.3	Not Available	Not Available	79.2	134	27.9	47.3
	min	0.98	1.66	Available	Available	2.80	4.75	0.98	1.66
150 psig (10,3 bar G)	max	27.9	47.3	Not Available	Not Available	79.2	134	27.9	47.3
	min	0.82	1.41	Available	Available	2.34	3.98	0.82	1.41
200 psig (13,8 bar G)	max	27.9	47.3	Not Available	Not Available	79.2	134	27.9	47.3
	min	0.82	1.41	Available	Available	2.34	3.98	0.82	1.41
300 psig (20,7 bar G)	max	27.9	47.3	Not Available	Not Available	79.2	134	27.9	47.3
	min	0.82	1.41	Available	Available	2.34	3.98	0.82	1.41
400 psig (27,6 bar G)	max	25.7	43.9	Not Available	Not Available	73.0	124	25.7	43.9
	min	0.82	1.41	Available	Available	2.34	3.98	0.82	1.41
500 psig (34,5 bar G)	max	23.0	39.4	Not Available	Not Available	66.0	112	23.0	39.4
	min	0.82	1.41	Available	Available	2.34	3.98	0.82	1.41

**Table 11. Air Flow Rate Limits at 59 °F (15 °C)**

Process Pressure	Flow Rate Limits	Minimum and Maximum Air Flow Rates for line sizes 1 1/2-in./DN 40 through 2-in./DN 50							
		1 1/2-in./DN 40				2-in./DN 50			
		Rosemount 8800D		Rosemount 8800DR		Rosemount 8800D		Rosemount 8800DR	
		ACFM	ACMH	ACFM	ACMH	ACFM	ACMH	ACFM	ACMH
0 psig (0 bar G)	max	212	360	79.2	134	349	593	212	360
	min	18.4	31.2	9.71	16.5	30.3	51.5	18.4	31.2
50 psig (3,45 bar G)	max	212	360	79.2	134	349	593	212	360
	min	8.76	14.9	3.72	6.32	14.5	24.6	8.76	14.9
100 psig (6,89 bar G)	max	212	360	79.2	134	349	593	212	360
	min	6.58	11.2	2.80	4.75	10.8	18.3	6.58	11.2
150 psig (10,3 bar G)	max	212	360	79.2	134	349	593	212	360
	min	5.51	9.36	2.34	3.98	9.09	15.4	5.51	9.36
200 psig (13,8 bar G)	max	212	360	79.2	134	349	593	212	360
	min	5.51	9.36	2.34	3.98	9.09	15.4	5.51	9.36
300 psig (20,7 bar G)	max	198	337	79.2	134	326	554	198	337
	min	5.51	9.36	2.34	3.98	9.09	15.4	5.51	9.36
400 psig (27,6 bar G)	max	172	293	73.0	124	284	483	172	293
	min	5.51	9.36	2.34	3.98	9.09	15.4	5.51	9.36
500 psig (34,5 bar G)	max	154	262	66.0	112	254	432	154	262
	min	5.51	9.36	2.34	3.98	9.09	15.4	5.51	9.36

**Table 12. Air Flow Rate Limits at 59 °F (15 °C)**

Process Pressure	Flow Rate Limits	Minimum and Maximum Air Flow Rates for line sizes 3-in./DN 80 through 4-in./DN 100							
		3-in./DN 80				4-in./DN 100			
		Rosemount 8800D		Rosemount 8800DR		Rosemount 8800D		Rosemount 8800DR	
		ACFM	ACMH	ACFM	ACMH	ACFM	ACMH	ACFM	ACMH
0 psig (0 bar G)	max	770	1308	349	593	1326	2253	770	1308
	min	66.8	114	30.3	51.5	115	195	66.8	114
50 psig (3,45 bar G)	max	770	1308	349	593	1326	2253	770	1308
	min	31.8	54.1	14.5	24.6	54.8	93.2	31.8	54.1
100 psig (6,89 bar G)	max	770	1308	349	593	1326	2253	770	1308
	min	23.9	40.6	10.8	18.3	41.1	69.8	23.9	40.6
150 psig (10,3 bar G)	max	770	1308	349	593	1326	2253	770	1308
	min	20.0	34.0	9.09	15.4	34.5	58.6	20.0	34.0
200 psig (13,8 bar G)	max	770	1308	349	593	1326	2253	770	1308
	min	20.0	34.0	9.09	15.4	34.5	58.6	20.0	34.0
300 psig (20,7 bar G)	max	718	1220	326	554	1237	2102	718	1220
	min	20.0	34.0	9.09	15.4	34.5	58.6	20.0	34.0
400 psig (27,6 bar G)	max	625	1062	284	483	1076	1828	625	1062
	min	20.0	34.0	9.09	15.4	34.5	58.6	20.0	34.0
500 psig (34,5 bar G)	max	560	951	254	432	964	1638	560	951
	min	20.0	34.0	9.09	15.4	34.5	58.6	20.0	34.0

**Table 13. Air Flow Rate Limits at 59 °F (15 °C)**

Process Pressure	Flow Rate Limits	Minimum and Maximum Air Flow Rates for line sizes 6-in./DN 150 through 8-in./DN 200							
		6-in./DN 150				8-in./DN 200			
		Rosemount 8800D		Rosemount 8800DR		Rosemount 8800D		Rosemount 8800DR	
		ACFM	ACMH	ACFM	ACMH	ACFM	ACMH	ACFM	ACMH
0 psig (0 bar G)	max	3009	5112	1326	2253	5211	8853	3009	5112
	min	261	443	115	195	452	768	261	443
50 psig (3,45 bar G)	max	3009	5112	1326	2253	5211	8853	3009	5112
	min	124	211	54.8	93.2	215	365	124	211
100 psig (6,89 bar G)	max	3009	5112	1326	2253	5211	8853	3009	5112
	min	93.3	159	41.1	69.8	162	276	93.3	159
150 psig (10,3 bar G)	max	3009	5112	1326	2253	5211	8853	3009	5112
	min	78.2	133	34.5	58.6	135	229	78.2	133
200 psig (13,8 bar G)	max	3009	5112	1326	2253	5211	8853	3009	5112
	min	78.2	133	34.5	58.6	135	229	78.2	133
300 psig (20,7 bar G)	max	2807	4769	1237	2102	4862	8260	2807	4769
	min	78.2	133	34.5	58.6	135	229	78.2	133
400 psig (27,6 bar G)	max	2442	4149	1076	1828	4228	7183	2442	4149
	min	78.2	133	34.5	58.6	136	229	78.2	133
500 psig (34,5 bar G)	max	2188	3717	964	1638	3789	6437	2188	3717
	min	78.2	133	34.5	58.6	136	229	78.2	133

**Table 14. Air Flow Rate Limits at 59 °F (15 °C)**

Process Pressure	Flow Rate Limits	Minimum and Maximum Air Flow Rates for line sizes 10-in./DN 250 through 12-in./DN 300							
		10-in./DN 250				12-in./DN 300			
		Rosemount 8800D		Rosemount 8800DR		Rosemount 8800D		Rosemount 8800DR	
		ACFM	ACMH	ACFM	ACMH	ACFM	ACMH	ACFM	ACMH
0 psig (0 bar G)	max	8214	13956	5211	8853	11781	20016	8214	13956
	min	712.9	1211	452	768	1022	1736	712.9	1211
50 psig (3,45 bar G)	max	8214	13956	5211	8853	11781	20016	8214	13956
	min	339.5	577	215	365	486.9	827	339.5	577
100 psig (6,89 bar G)	max	8214	13956	5211	8853	11781	20016	8214	13956
	min	254.7	433	162	276	365.4	621	254.7	433
150 psig (10,3 bar G)	max	8214	13956	5211	8853	11781	20016	8214	13956
	min	213.6	363	135	229	306.3	520	213.6	363
200 psig (13,8 bar G)	max	8214	13956	5211	8853	11781	20016	8214	13956
	min	213.6	363	135	229	306.3	520	213.6	363
300 psig (20,7 bar G)	max	7664	13021	4862	8260	10992	18675	7664	13021
	min	213.6	363	135	229	306.3	520	213.6	363
400 psig (27,6 bar G)	max	6664	11322	4228	7183	9559	16241	6664	11322
	min	213.6	363	136	229	306.3	520	213.6	363
500 psig (34,5 bar G)	max	5972	10146	3789	6437	8565	14552	5972	10146
	min	213.6	363	136	229	306.3	520	213.6	363

**NOTE**

The Rosemount 8800D measures the volumetric flow under operating conditions (i.e. the actual volume at the operating pressure and temperature—acfm or acmh), as shown above. However, gas volumes are strongly dependent on pressure and temperature. Therefore, gas quantities are typically stated in standard or normal conditions (e.g. SCFM or NCMH). (Standard conditions are typically 59 °F and 14.7 psia. Normal conditions are typically 0 °C and 1.01 bar abs.)

The flow rate limits in standard conditions are found using the equations below:

$$\text{Standard Flow Rate} = \text{Actual Flow Rate} \times \text{Density Ratio}$$

$$\text{Density Ratio} = \text{Density at Actual (Operating) Conditions} / \text{Density at Standard Conditions}$$

**Table 15. Saturated Steam Flow Rate Limits (Assumes Steam Quality is 100%)**

Process Pressure	Flow Rate Limits	Minimum and Maximum Saturated Steam Flow Rates for line sizes 1/2-in./DN 15 through 1-in./DN 25							
		1/2-in./DN 15				1-in./DN 25			
		Rosemount 8800D		Rosemount 8800DR		Rosemount 8800D		Rosemount 8800DR	
		lb/hr	kg/hr	lb/hr	kg/hr	lb/hr	kg/hr	lb/hr	kg/hr
15 psig (1,03 bar G)	max	120	54.6	Not Available	Not Available	342	155	120	54.6
	min	12.8	5.81	Available	Available	34.8	15.8	12.8	5.81
25 psig (1,72 bar G)	max	158	71.7	Not Available	Not Available	449	203	158	71.7
	min	14.0	6.35	Available	Available	39.9	18.1	14.0	6.35
50 psig (3,45 bar G)	max	250	113	Not Available	Not Available	711	322	250	113
	min	17.6	8.00	Available	Available	50.1	22.7	17.6	8.00
100 psig (6,89 bar G)	max	429	194	Not Available	Not Available	1221	554	429	194
	min	23.1	10.5	Available	Available	65.7	29.8	23.1	10.5
150 psig (10,3 bar G)	max	606	275	Not Available	Not Available	1724	782	606	275
	min	27.4	12.5	Available	Available	78.1	35.4	27.4	12.5
200 psig (13,8 bar G)	max	782	354	Not Available	Not Available	2225	1009	782	354
	min	31.2	14.1	Available	Available	88.7	40.2	31.2	14.1
300 psig (20,7 bar G)	max	1135	515	Not Available	Not Available	3229	1464	1135	515
	min	37.6	17.0	Available	Available	107	48.5	37.6	17.0
400 psig (27,6 bar G)	max	1492	676	Not Available	Not Available	4244	1925	1492	676
	min	44.1	20.0	Available	Available	125	56.7	44.1	20.0
500 psig (34,5 bar G)	max	1855	841	Not Available	Not Available	5277	2393	1855	841
	min	54.8	24.9	Available	Available	156	70.7	54.8	24.9

**Table 16. Saturated Steam Flow Rate Limits (Assumes Steam Quality is 100%)**

Process Pressure	Flow Rate Limits	Minimum and Maximum Saturated Steam Flow Rates for line sizes 1 1/2-in./DN 40 through 2-in./DN 50							
		1 1/2-in./DN 40				2-in./DN 50			
		Rosemount 8800D		Rosemount 8800DR		Rosemount 8800D		Rosemount 8800DR	
		lb/hr	kg/hr	lb/hr	kg/hr	lb/hr	kg/hr	lb/hr	kg/hr
15 psig (1,03 bar G)	max	917	416	342	155	1511	685	917	416
	min	82.0	37.2	34.8	15.8	135	61.2	82.0	37.2
25 psig (1,72 bar G)	max	1204	546	449	203	1983	899	1204	546
	min	93.9	42.6	39.9	18.1	155	70.2	93.9	42.6
50 psig (3,45 bar G)	max	1904	864	711	322	3138	1423	1904	864
	min	118	53.4	50.1	22.7	195	88.3	118	53.4
100 psig (6,89 bar G)	max	3270	1483	1221	554	5389	2444	3270	1483
	min	155	70.1	65.7	29.8	255	116	155	70.1
150 psig (10,3 bar G)	max	4616	2094	1724	782	7609	3451	4616	2094
	min	184	83.2	78.1	35.4	303	137	184	83.2
200 psig (13,8 bar G)	max	5956	2702	2225	1009	9818	4453	5956	2702
	min	209	94.5	88.7	40.2	344	156	209	94.5
300 psig (20,7 bar G)	max	8644	3921	3229	1464	14248	6463	8644	3921
	min	252	114	107	48.5	415	189	252	114
400 psig (27,6 bar G)	max	11362	5154	4244	1925	18727	8494	11362	5154
	min	295	134	125	56.7	487	221	295	134
500 psig (34,5 bar G)	max	14126	6407	5277	2393	23284	10561	14126	6407
	min	367	167	156	70.7	605	274	367	167

**Table 17. Saturated Steam Flow Rate Limits (Assumes Steam Quality is 100%)**

Process Pressure	Flow Rate Limits	Minimum and Maximum Saturated Steam Flow Rates for line sizes 3-in./DN 80 through 4-in./DN 100							
		3-in./DN 80				4-in./DN 100			
		Rosemount 8800D		Rosemount 8800DR		Rosemount 8800D		Rosemount 8800DR	
		lb/hr	kg/hr	lb/hr	kg/hr	lb/hr	kg/hr	lb/hr	kg/hr
15 psig (1,03 bar G)	max	3330	1510	1511	685	5734	2601	3330	1510
	min	298	135	135	61.2	513	233	298	135
25 psig (1,72 bar G)	max	4370	1982	1983	899	7526	3414	4370	1982
	min	341	155	155	70.2	587	267	341	155
50 psig (3,45 bar G)	max	6914	3136	3138	1423	11905	5400	6914	3136
	min	429	195	195	88.3	739	335	429	195
100 psig (6,89 bar G)	max	11874	5386	5389	2444	20448	9275	11874	5386
	min	562	255	255	116	968	439	562	255
150 psig (10,3 bar G)	max	16763	7603	7609	3451	28866	13093	16763	7603
	min	668	303	303	137	1150	522	668	303
200 psig (13,8 bar G)	max	21630	9811	9818	4453	37247	16895	21630	9811
	min	759	344	344	156	1307	593	759	344
300 psig (20,7 bar G)	max	31389	14237	14248	6463	54052	24517	31389	14237
	min	914	415	415	189	1574	714	914	415
400 psig (27,6 bar G)	max	41258	18714	18727	8494	71047	32226	41258	18714
	min	1073	487	487	221	1847	838	1073	487
500 psig (34,5 bar G)	max	51297	23267	23284	10561	88334	40068	51297	23267
	min	1334	605	605	274	2297	1042	1334	605

**Table 18. Saturated Steam Flow Rate Limits (Assumes Steam Quality is 100%)**

Process Pressure	Flow Rate Limits	Minimum and Maximum Saturated Steam Flow Rates for line sizes 6-in./DN 150 through 8-in./DN 200							
		6-in./DN 150				8-in./DN 200			
		Rosemount 8800D		Rosemount 8800DR		Rosemount 8800D		Rosemount 8800DR	
		lb/hr	kg/hr	lb/hr	kg/hr	lb/hr	kg/hr	lb/hr	kg/hr
15 psig (1,03 bar G)	max	13013	5903	5734	2601	22534	10221	13013	5903
	min	1163	528	513	233	2015	914	1163	528
25 psig (1,72 bar G)	max	17080	7747	7526	3414	29575	13415	17080	7747
	min	1333	605	587	267	2308	1047	1333	605
50 psig (3,45 bar G)	max	27019	12255	11905	5400	46787	21222	27019	12255
	min	1676	760	739	335	2903	1317	1676	760
100 psig (6,89 bar G)	max	46405	21049	20448	9275	80356	36449	46405	21049
	min	2197	996	968	439	3804	1725	2197	996
150 psig (10,3 bar G)	max	65611	29761	28866	13093	113440	51455	65611	29761
	min	2610	1184	1150	522	4520	2050	2610	1184
200 psig (13,8 bar G)	max	84530	38342	37247	16895	146375	66395	84530	38342
	min	2965	1345	1307	593	5134	2329	2965	1345
300 psig (20,7 bar G)	max	122666	55640	54052	24517	212411	96348	122666	55640
	min	3572	1620	1574	714	6185	2805	3572	1620
400 psig (27,6 bar G)	max	161236	73135	71047	32226	279200	126643	161236	73135
	min	4192	1901	1847	838	7259	3293	4192	1901
500 psig (34,5 bar G)	max	200468	90931	88334	40068	347134	157457	200468	90931
	min	5212	2364	2297	1042	9025	4094	5212	2364



**Table 19. Saturated Steam Flow Rate Limits (Assumes Steam Quality is 100%)**

Process Pressure	Flow Rate Limits	Minimum and Maximum Saturated Steam Flow Rates for line sizes 10-in./DN 250 through 12-in./DN 300							
		10-in./DN 250				12-in./DN 300			
		Rosemount 8800D		Rosemount 8800DR		Rosemount 8800D		Rosemount 8800DR	
		lb/hr	kg/hr	lb/hr	kg/hr	lb/hr	kg/hr	lb/hr	kg/hr
15 psig (1,03 bar G)	max	35519	16111	22534	10221	50994	23130	35519	16111
	min	3175	1440	2015	914	4554	2066	3175	1440
25 psig (1,72 bar G)	max	46618	21146	29575	13415	66862	30328	46618	21146
	min	4570	2073	2308	1047	5218	2367	4570	2073
50 psig (3,45 bar G)	max	73748	33452	46787	21222	105774	47978	73748	33452
	min	4575	2075	2903	1317	6562	2976	4575	2075
100 psig (6,89 bar G)	max	126660	57452	80356	36449	181663	82401	126660	57452
	min	5996	2720	3804	1725	8600	3901	5996	2720
150 psig (10,3 bar G)	max	178808	81106	113440	51455	256457	116327	178808	81106
	min	7125	3232	4520	2050	10218	4635	7125	3232
200 psig (13,8 bar G)	max	230722	104654	146375	66395	330915	150101	230722	104654
	min	8092	3670	5134	2329	11607	5265	8092	3670
300 psig (20,7 bar G)	max	334810	151867	212411	96348	480203	217816	334810	151867
	min	9749	4422	6185	2805	13983	6343	9749	4422
400 psig (27,6 bar G)	max	440085	199619	279200	126643	631195	286305	440085	199619
	min	11442	5190	7259	3293	16411	7444	11442	5190
500 psig (34,5 bar G)	max	547165	248190	347134	157457	784775	355968	547165	248190
	min	14226	6453	9025	4094	20404	9255	14226	6453

## Performance Specifications

The following performance specifications are for all Rosemount models except where noted. Digital performance specifications applicable to both Digital HART and FOUNDATION fieldbus output.

### Flow Accuracy

Includes linearity, hysteresis, and repeatability.

### Liquids - for Reynolds Numbers over 20000

#### Digital and Pulse Output

±0.65% of rate

Note: The accuracy for the 8800DR, line sizes 6 to 12-in. (150 to 300mm), is ±1.0% of rate.

#### Analog Output

Same as pulse output plus an additional 0.025% of span

### Gas and Steam - for Reynolds Numbers over 15,000

#### Digital and Pulse Output

±1.0% of rate

Note: The accuracy for the 8800DR, line sizes 6 to 12-in. (150 to 300mm), is ±1.35% of rate.

### Analog Output

Same as pulse output plus an additional 0.025% of span

### Accuracy limitations for gas and steam:

For 1/2 and 1-in. (DN 15 and DN 25): max velocity of 220 ft/s (67.06 m/s)

For 1/2 to 4-in. (DN 15 to DN 200) Dual-style meters: max velocity of 100 ft/s (30.5 m/s)

### Note

As the meter Reynolds Numbers decreases below the stated limit to 10,000 the accuracy error band will increase linearly to +/-2.0%. For Reynolds Numbers down to 5,000 the accuracy error band will increase linearly from +/-2.0% to +/-6.0%.

### Process Temperature Accuracy

2.2 °F (1.2 °C) or 0.4% of reading (in °C), whichever is greater.

### Note

For remote mount installations, add ±0.018 °F/ft. (±0.03 °C/m) of uncertainty to the temperature measurement.

### Mass Flow Accuracy for Temperature Compensated Mass Flow

± 2.0% of rate (Typical)

#### Repeatability

± 0.1% of actual flow rate

#### Stability

± 0.1% of rate over one year

### Process Temperature Effect

Automatic K-factor correction with user-entered process temperature.

Table 20 indicates the percent change in K-factor per 100 °F (55.6 °C) in process temperature from reference temperature of 77 °F (25 °C).

**Table 20. Process Temperature Effect**

Material	Percent Change in K-Factor per 100 °F (55.6 °C)
316L @ < 77 °F (25 °C)	+ 0.23
316L @ > 77 °F (25 °C)	- 0.27
Nickel Alloy C < 77 °F (25 °C)	+ 0.22
Nickel Alloy C > 77 °F (25 °C)	- 0.22

### Ambient Temperature Effect

#### Digital and Pulse Outputs

No effect

#### Analog Output

±0.1% of span from -58 to 185 °F (-50 to 85 °C)

### Vibration Effect

An output with no process flow may be detected if sufficiently high vibration is present.

The meter design will minimize this effect, and the factory settings for signal processing are selected to eliminate these errors for most applications.

If an output error at zero flow is still detected, it can be eliminated by adjusting the low flow cutoff, trigger level, or low-pass filter.

As the process begins to flow through the meter, most vibration effects are quickly overcome by the flow signal.

### Vibration Specifications

#### Integral Aluminum Housings, Remote Aluminum Housings, and Remote SST Housings

At or near the minimum liquid flow rate in a normal pipe mounted installation, the maximum vibration should be 0.087-in. (2,21 mm) double amplitude displacement or 1 g acceleration, whichever is smaller. At or near the minimum gas flow rate in a normal pipe mounted installation, the maximum vibration should be 0.043-in. (1,09 mm) double amplitude displacement or 1/2 g acceleration, whichever is smaller.

#### Integral SST Housing

At or near the minimum liquid flow rate in a normal pipe mounted installation, the maximum vibration should be 0.044-in. (1,11 mm) double amplitude displacement or 1/3 g acceleration, whichever is smaller. At or near the minimum gas flow rate in a normal pipe mounted installation, the maximum vibration should be 0.022-in. (0,55 mm) double amplitude displacement or 1/6 g acceleration, whichever is smaller.

### Mounting Position Effect

Meter will meet accuracy specifications when mounted in horizontal, vertical, or inclined pipelines. Best practice for mounting in a horizontal pipe is to orient the shedder bar in the horizontal plane. This will prevent solids in liquid applications and liquid in gas/steam applications from disrupting the shedding frequency.

### EMI/RFI Effect

Meets EMC requirements to EU Directive 2004/108/EC.

#### HART Analog

Output error less than ±0.025% of span with twisted pair from 80-1000 MHz for radiated field strength of 10 V/m; 1.4 - 2.0 GHz for radiated field strength of 3 V/m; 2.0 - 2.7 GHz for radiated field strength of 1 V/m. Tested per EN61326.

#### FOUNDATION fieldbus and Digital HART

No affect on the values that are being given if using HART digital signal or FOUNDATION fieldbus. Tested per EN 61326.

### Magnetic-Field Interference

#### HART Analog

Output error less than ±0.025% of span at 30 A/m (rms). Tested per EN 61326.

#### FOUNDATION fieldbus

No effect on digital output accuracy at 30 A/m (rms). Tested per EN 61326.

### Series Mode Noise Rejection

#### HART Analog

Output error less than ±0.025% of span at 1 V rms, 60 Hz.

**FOUNDATION fieldbus**

No effect on digital output accuracy at 1 V rms, 60 Hz.

**Common Mode Noise Rejection****HART Analog**

Output error less than  $\pm 0.025\%$  of span at 30 V rms, 60 Hz.

**FOUNDATION fieldbus**

No effect on digital output accuracy at 250 V rms, 60 Hz.

**Power Supply Effect****HART Analog**

Less than 0.005% of span per volt

**FOUNDATION fieldbus**

No effect on accuracy.

## Physical Specifications

**NACE Compliance**

Materials of Construction meet NACE material recommendations per MR0175/ISO15156 for use in H<sub>2</sub>S containing environments in oil field production. Materials of construction also meet NACE recommendations per MR0103-2003 for corrosive petroleum refining environments. MR0103 compliance requires Q25 option in model code.

**NOTE:**

Certificate of compliance for MR0175/ISO15156 requires Q15 as a separate line item.

**Electrical Connections**

$1/2$ –14 or M20  $\times$  1.5 conduit threads; screw terminals provided for 4–20 mA, FOUNDATION Fieldbus, and pulse output connections; communicator connections permanently fixed to terminal block.

**Non-Wetted Materials****Housing**

Low-copper aluminum (FM Type 4X, CSA Type 4X, IP66)  
Optional SST housing

**Paint**

Polyurethane

**Cover O-rings**

Buna-N

**Flanges**

316/316L lap joint

**Temperature Sensor (MTA Option)**

Type-N Thermocouple

**Process-Wetted Materials****Meter Body**

316L wrought stainless and CF-3M cast stainless or N06022 wrought Nickel Alloy and CW2M cast Nickel Alloy. Other material grades available. Consult factory for other materials of construction.

**Flanges**

316/316L stainless steel  
Nickel Alloy N06022 Weld Neck

**Collars**

Nickel Alloy N06022  
316/316L Stainless Steel

**Surface Finish of Flanges and Collars**

Standard: To the requirements of the applicable flange standard.

Smooth: 63 to 125  $\mu$  inches  
(1.6 to 3.1  $\mu$  meters) Ra roughness

**Process Connections**

Mounts between the following flange configurations:  
 ASME B16.5: Class 150, 300, 600, 900, 1500  
 EN 1092-1: PN 10, 16, 25, 40, 64, 100, 160  
 JIS B2220: 10K, 20K, and 40K  
 Weld-end: Schedule 10, Schedule 40, Schedule 80, Schedule 160

**Mounting**

**Integral (Standard)**

Electronics are mounted on meter body.

**Remote (Optional)**

Electronics may be mounted remote from the meter body. Interconnecting coaxial cable available in nonadjustable 10, 20, 30, 33, and 50 ft (3,0, 6,1, 9,1, 10, and 15,2 m) lengths. Consult factory for non-standard lengths up to 75 ft (22,9 m). Remote mounting hardware includes a pipe mount bracket with one u-bolt.

**Temperature Limitations for Integral Mounting**

The maximum process temperature for integral mount electronics is dependent on the ambient temperature where the meter is installed. The electronics must not exceed 185 °F (85 °C). The following is for reference, please note that the pipe was insulated with 3 inches of ceramic fiber insulator.

**Figure 1. Rosemount 8800 Vortex Flowmeter Ambient/process temperature limits**

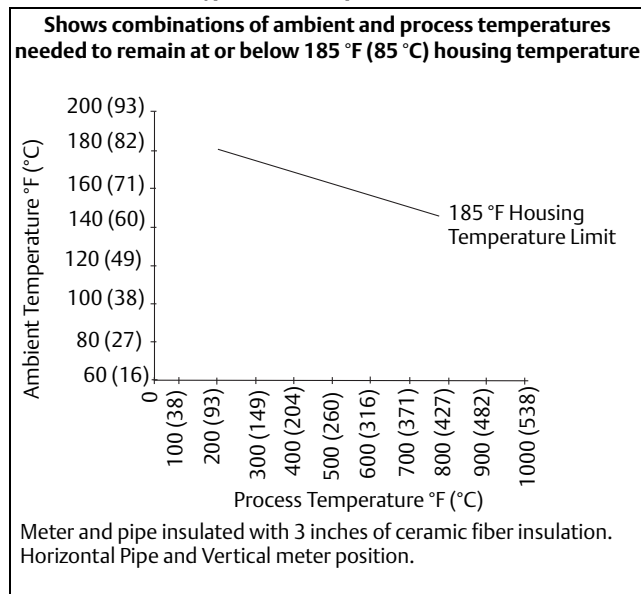

**Pipe Length Requirements**

The vortex meter may be installed with a minimum of ten diameters (D) of straight pipe length upstream and five diameters (D) of straight pipe length downstream.

Rated Accuracy is based on the number of pipe diameter from an upstream disturbance. No K-factor correction is required if the meter is installed with 35 D upstream and 10 D downstream. The value of the K-factor may shift up to 0.5% when the upstream straight pipe length is between 10D and 35D. Please see Technical Data Sheet (00816-0100-3250) on Installation Effects for optional K-factor corrections. This effect can be corrected in the electronics.

**Tagging**

The flowmeter will be tagged at no charge. All tags are stainless steel. The standard tag is permanently attached to the flowmeter. Character height is 1/16-in. (1,6 mm). A wired-on tag is available on request. Character height on the wire-on tag is 0.236-in. (6 mm). Wire on tags can contain five lines with an average of 19 characters per line at standard character height.

**Flow Calibration Information**

Flowmeter calibration and configuration information is provided with every flowmeter. For a certified copy of flow calibration data, Option Q4 must be ordered in the model number.

# Product Certifications

## Approved Manufacturing Locations

Rosemount Inc. — Eden Prairie, Minnesota, USA

Emerson Process Management BV - Ede, The Netherlands

Emerson Process Management Flow Technologies Company, Ltd  
- Nanjing, Jiangsu Province, P.R. China

### Flameproof enclosure Ex d protection type in accordance with IEC 60079-1, EN 60079-1

- Transmitters with Flameproof enclosure type protection shall only be opened when power is removed.
- Closing of entries in the device must be carried out using the appropriate Ex d cable gland or blanking plug. Unless otherwise marked on housing, the standard conduit entry thread forms are 1/2-14 NPT.

### Type n protection type in accordance with IEC 60079-15, EN60079-15

- Closing of entries in the device must be carried out using the appropriate Ex e or Ex n cable gland and metal blanking plug or any appropriate ATEX or IECEx approved cable gland and blanking plug with IP66 rating certified by an EU approved certification body.

### European Directive Information

The CE Declaration of Conformity for all applicable European directives for this product can be found on our website at [www.rosemount.com](http://www.rosemount.com). A hard copy may be obtained by contacting our local sales office.

### ATEX Directive

Rosemount Inc. complies with the ATEX Directive.

### European Pressure Equipment Directive (PED)

#### Rosemount 8800D Vortex Flowmeter Line Size 40 mm to 300 mm

Certificate Number 59552-2009-CE-HOU-DNV  
CE 0575

Module H Conformity Assessment

Mandatory CE-marking for flowmeters in accordance with Article 15 of the PED can be found on the flowtube body. Flowmeter categories I – III use module H for conformity assessment procedures.

#### Rosemount 8800D Vortex Flowmeter Line Size 15 mm and 25 mm

### Sound Engineering Practice

Flowmeters that are SEP are outside the scope of PED and cannot be marked for compliance with PED.

## Hazardous Location Certifications

### Rosemount 8800D

#### North American Certifications

##### Factory Mutual (FM)

- E5** Explosion-proof for Class I, Division 1, Groups B, C, and D; Dust Ignition-proof for Class II/III, Division 1, Groups E, F, and G;  
Temp Code T6 ( $-50\text{ °C} \leq T_a \leq 70\text{ °C}$ )  
Factory Sealed  
Enclosure Type 4X and IP66
- I5** Intrinsically safe for use in Class I, II, III Division 1, Groups A, B, C, D, E, F, G;  
Non-incendive for Class I, Division 2, Groups A, B, C, and D. NIFW (Non-incendive Field Wiring) when installed per Rosemount Drawing 08800-0116  
Temperature Code T4 ( $-50\text{ °C}$  to  $70\text{ °C}$ ) 4-20 mA HART  
Temperature Code T4 ( $-50\text{ °C}$  to  $60\text{ °C}$ ) Fieldbus  
Enclosure Type 4X and IP66
- IE** FISCO for Class I, Division 1, Groups A, B, C, and D. FNICO for Class 1 Division 2, Groups A, B, C, and D. Temperature Code T4 ( $-50\text{ °C} \leq T_a \leq 60\text{ °C}$ ) when installed per Rosemount Drawing 08800-0116  
Enclosure Type 4X and IP66

##### K5 E5 and I5 Combination

Special conditions for safe use (x)

When fitted with 90 V transient suppressors (T1 Option), the equipment is not capable of passing the 500 V insulation test. This must be taken into account upon installation.

The Model 8800D Vortex Flowmeter, when ordered with aluminum electronics housing, is considered to constitute a potential risk of ignition by impact or friction. Care should be taken into account during installation and use to prevent impact or friction.

#### Canadian Standards Association (CSA)

- Pollution degree 2
- Installation category II
- Altitude 2,000 m
- Humidity 0 to 90%
- Electrical supply 42 VDC maximum
- Temperature  $-50\text{ °C}$  to  $85\text{ °C}$

- E6** Explosion-Proof for Class I, Division 1, Groups B, C, and D; Dust-ignition proof for Class II/Class III, Division 1, Groups E, F, and G; Class I, Zone 1, Ex d[ia] IIC CSA 06.1674267 Temperature Code T6 (-50 °C ≤ T<sub>a</sub> ≤ 70 °C) Factory Sealed Single Seal. Enclosure Type 4X.
- I6** Intrinsically safe for use in Class I, II, III Division 1, Groups A, B, C, D, E, F, G; Non-incendive for Class I, Division 2, Groups A, B, C and D Temperature Code T4 (-50 °C ≤ T<sub>a</sub> ≤ 70 °C) 4-20 mA HART Temperature Code T4 (-50 °C ≤ T<sub>a</sub> ≤ 60 °C) Fieldbus Single Seal. Enclosure Type 4X.
- IF** FISCO for Class I, Division 1, Groups A, B, C, and D; FNIC0 for Class 1 Division 2, Groups A, B, C, and D. Temperature Code T4 (-50 °C ≤ T<sub>a</sub> ≤ 60 °C). When installed per Rosemount drawing 08800-0112 Enclosure Type 4X

**K6** E6 and I6 Combination

**Combination Certifications**

**KB** E5, I5, E6, and I6 Combination

**European Certifications**

**ATEX Intrinsic Safety**

EN 60079-0: 2009  
EN 60079-11: 2007

- I1** Certification No. Baseefa05ATEX0084X  
ATEX Marking Ⓜ II 1 G  
Ex ia IIC T4 Ga (-60 °C ≤ T<sub>a</sub> ≤ 70 °C) 4-20 mA HART  
(-60 °C ≤ T<sub>a</sub> ≤ 60 °C) Fieldbus

4-20 mA HART Entity Parameters	Fieldbus Entity Parameters
U <sub>i</sub> = 30 VDC	U <sub>i</sub> = 30 VDC
I <sub>i</sub> <sup>(1)</sup> = 185 mA	I <sub>i</sub> = 300 mA
P <sub>i</sub> <sup>(1)</sup> = 1.0 W	P <sub>i</sub> = 1.3 W
C <sub>i</sub> = 0 μF	C <sub>i</sub> = 0 μF
L <sub>i</sub> < 0.97 mH	L <sub>i</sub> < 10 μH

(1) Total for transmitter

Ⓒ 0575

**ATEX FISCO/FNIC0**

- IA** Certification No. Baseefa05ATEX0084X  
ATEX Marking Ⓜ II 1 G  
Ex ia IIC T4 Ga (-60 °C ≤ T<sub>a</sub> ≤ 60 °C)  
Ⓒ 0575  
Input Parameters:  
U<sub>i</sub> = 17.5 Vdc  
I<sub>i</sub> = 380 mA  
P<sub>i</sub> = 5.32 W  
C<sub>i</sub> = 0 μF  
L<sub>i</sub> < 10 μH

**Special conditions for safe use (x)**

When fitted with 90V transient suppressors (T1 Option), the equipment is not capable of passing the 500V isolation test. This must be taken into account upon installation.

The enclosure may be made from aluminium alloy and given a protective polyurethane paint finish; however, care should be taken to protect it from impact or abrasion when located in Zone 0 environment. The polyurethane paint finish may constitute an electrostatic hazard and must only be cleaned with a damp cloth.

When the equipment is installed, particular precautions must be taken to ensure taking into account the effect of process fluid temperature, that the ambient temperature of the electrical housing of the equipment meets the marked protection type temperature range.

**ATEX Type N Certification**

EN 60079-0: 2009  
EN 60079-11: 2007  
EN 60079-15: 2010

- N1** Certification No. Baseefa05ATEX0085X  
ATEX Marking Ⓜ II 3 G  
Ex nA ic IIC T5 Gc (-50 °C ≤ T<sub>a</sub> ≤ 70 °C) 4 -20 mA HART  
(-50 °C ≤ T<sub>a</sub> ≤ 60 °C) Fieldbus

Input Parameters:  
Maximum Working Voltage = 42 Vdc 4-20 mA HART  
Maximum Working Voltage = 32 Vdc Fieldbus

**Special conditions for safe use (x)**

When fitted with 90V transient suppressors (T1 Option), the equipment is not capable of passing the 500V isolation test. This must be taken into account upon installation.

The enclosure may be made from aluminium alloy with a protective polyurethane paint finish. The polyurethane paint finish may constitute an electrostatic hazard and must only be cleaned with a damp cloth.

When the equipment is installed, particular precautions must be taken to ensure, taking into account the effect of process fluid temperature, that the ambient temperature of the electrical housing of the equipment meets the marked protection type temperature range.

**ATEX Flameproof Certification**

EN 60079-0: 2009  
 EN 60079-1: 2007  
 EN 60079-11: 2007  
 EN 60079-26: 2007

**E1** Certification No. KEMA99ATEX3852X

Integral Flowmeter marked:

⊕ II 1/2 G  
 Ex d [ia] IIC T6 Ga/Gb

(-50 °C ≤ T<sub>a</sub> ≤ 70 °C)

Remote Transmitter marked:

⊕ II 2(1) G  
 Ex d [ia Ga] IIC T6 Gb

(-50 °C ≤ T<sub>a</sub> ≤ 70 °C)

with meter body marked:

⊕ II 1 G Ex ia IIC T6 Ga

Maximum Working Voltage = 42 Vdc 4-20 mA HART

Maximum Working Voltage = 32 Vdc Fieldbus

Um = 250V

**Installation Instructions**

The cable and conduit entry devices shall be of a certified flameproof type Ex d, suitable for the conditions of use and correctly installed.

Unused apertures shall be closed with suitable blanking elements. When the ambient temperature at the cable or conduit entries exceed 60 °C, cables suitable for at least 90 °C shall be used.

Care must be taken when installing the equipment with process fluid in the range of -202 °C to +427 °C, as the ambient temperature for the electronics and electronics housing must stay in the temperature range of -50 °C to +70 °C.

Units marked with "Warning: Electrostatic Charging Hazard" may use non-conductive paint thicker than 0.2 mm. Precautions shall be taken to avoid ignition due to electrostatic charge on the enclosure.

**Special conditions for safe use (x)**

When fitted with 90V transient suppressors (T1 Option), the equipment is not capable of passing the 500V isolation test. This must be taken into account upon installation.

The enclosure may be made from aluminium alloy and given a protective polyurethane paint finish; however, care should be taken to protect it from impact or abrasion when located in Zone 0 environment. The polyurethane paint finish may constitute an electrostatic hazard and must only be cleaned with a damp cloth.

When the equipment is installed, particular precautions must be taken to ensure, taking into account the effect of process fluid temperature, that the ambient temperature of the electrical housing of the equipment meets the marked protection type temperature range.

**Special conditions for safe use (x)**

For information regarding the dimensions of the flameproof joints the manufacturer shall be contacted.

The Flowmeter shall be provided with special fasteners of property class A2-70 or A4-70.

The remote mounted sensor may only be connected to the transmitter with the associated cable, supplied by the manufacturer.

**ATEX Dust Certification**

EN 61241-0: 2006

EN 61241-1: 2004

**ND** Certification No. Baseefa05ATEX0086/3

⊕ II 1D Ex tD A20 IP66 T90 °C (-20 °C ≤ T<sub>a</sub> ≤ 70 °C)  
 Maximum Working Voltage = 42 Vdc 4-20 mA HART

Maximum Working Voltage = 32 Vdc Fieldbus

**K1** E1, I1, N1 and ND Combination

**International IECEx Certifications**

**Intrinsic Safety**

IEC 60079-0: 2007

IEC 60079-11: 2006

**I7** Certification No. IECEx BAS05.0028X

Ex ia IIC T4 Ga (-60 °C ≤ T<sub>a</sub> ≤ 70 °C) 4-20 mA HART  
 (-60 °C ≤ T<sub>a</sub> ≤ 60 °C) Fieldbus

4-20 mA HART Entity Parameters		Fieldbus Entity Parameters	
U <sub>i</sub>	= 30 VDC	U <sub>i</sub>	= 30 VDC
I <sub>i</sub> <sup>(1)</sup>	= 185 mA	I <sub>i</sub>	= 300 mA
P <sub>i</sub> <sup>(1)</sup>	= 1.0 W	P <sub>i</sub>	= 1.3 W
C <sub>i</sub>	= 0 μF	C <sub>i</sub>	= 0 μF
L <sub>i</sub>	< 0.97 mH	L <sub>i</sub>	< 10 μH

(1) Total for transmitter.



**FISCO/FNICO**

**IG** Certification No. IECEx BAS 05.0028X  
 Ex ia IIC T4 Ga (-60 °C ≤ T<sub>a</sub> ≤ 60 °C)  
 Input Parameters:  
 U<sub>i</sub> = 17.5 Vdc  
 I<sub>i</sub> = 380 mA  
 P<sub>i</sub> = 5.32 W  
 C<sub>i</sub> = 0 μF  
 L<sub>i</sub> < 10 μH

**Type N Certification**

IEC 60079-0: 2007  
 IEC 60079-11: 2006  
 IEC 60079-15: 2010

**N7** Certification No. IECEx BAS05.0029X  
 Ex nA ic IIC T5 Gc (-50 °C ≤ T<sub>a</sub> ≤ 70 °C) 4-20 mA HART  
 (-50 °C ≤ T<sub>a</sub> ≤ 60 °C) Fieldbus

Maximum Working Voltage = 42 Vdc 4-20 mA HART  
 Maximum Working Voltage = 32 Vdc Fieldbus

**Special conditions for safe use (x)**

When fitted with 90V transient suppressors (T1 Option), the equipment is not capable of passing the 500V isolation test. This must be taken into account upon installation.

The enclosure may be made from aluminium alloy with a protective polyurethane paint finish. The polyurethane paint finish may constitute an electrostatic hazard and must only be cleaned with a damp cloth.

When the equipment is installed, particular precautions must be taken to ensure, taking into account the effect of process fluid temperature, that the ambient temperature of the electrical housing of the equipment meets the marked protection type temperature range.

**Flameproof Certification**

IEC 60079-0: 2007-10  
 IEC 60079-1: 2007-04  
 IEC 60079-11: 2006-07  
 IEC 60079-26: 2006-08

**E7** Certification No. IECEx KEM05.0017X  
 Integral Flowmeter marked:  
 Ex d [ia] IIC T6 Ga/Gb (-50 °C ≤ T<sub>a</sub> ≤ 70 °C)  
 Remote Transmitter marked:  
 Ex d [ia Ga] IIC T6 Gb(-50 °C ≤ T<sub>a</sub> ≤ 70 °C)  
 with meter body marked:  
 Ex ia IIC T6 Ga

Maximum Working Voltage = 42 Vdc 4-20 mA HART  
 Maximum Working Voltage = 32 Vdc Fieldbus  
 U<sub>m</sub> = 250V

**Installation Instructions**

The cable and conduit entry devices shall be of a certified flameproof type Ex d, suitable for the conditions of use and correctly installed. Unused apertures shall be closed with suitable blanking elements. When the ambient temperature at the cable or conduit entries exceed 60 °C, cables suitable for at least 90 °C shall be used. Care must be taken when installing the equipment with process fluid in the range of -202 °C to +427 °C, as the ambient temperature for the electronics and electronics housing must stay in the temperature range of -50 °C to +70 °C.

The remote mounted sensor may only be connected to the transmitter with the associated cable, supplied by the manufacturer.

**Special conditions for safe use (x)**

For information regarding the dimensions of the flameproof joints, the manufacturer shall be contacted. The Flowmeter shall be provided with special fasteners of property class A2-70 or A4-70.

Units marked with "Warning:Electrostatic Charging Hazard" may use non-conductive paint thicker than 0.2 mm. Precautions should be taken to avoid ignition due to electrostatic charge on the enclosure.

**Chinese Certifications (NEPSI)**

**Flameproof Certification**

**E3** Certification No. GYJ12.1493X  
 Integral Flowmeter marked:  
 Ex d [ia] IIC T6 Ga/Gb (-50 °C ≤ T<sub>a</sub> ≤ 70 °C)  
 Remote Transmitter marked:  
 Ex d [ia Ga] IIC T6 Gb(-50 °C ≤ T<sub>a</sub> ≤ 70 °C)  
 with meter body marked:  
 Ex ia IIC T6 Ga)

**Intrinsic Safety**

**I3** Certification No. GYJ12.1106X  
 Ex ia II CT4 Ga (-60 °C ≤ T<sub>a</sub> ≤ 70 °C) 4-20 mA HART  
 Ex ia II CT4 Ga (-60 °C ≤ T<sub>a</sub> ≤ 60 °C) Fieldbus

4-20 mA HART Entity Parameters	Fieldbus Entity Parameters
U <sub>i</sub> = 30 VDC	U <sub>i</sub> = 30 VDC
I <sub>i</sub> <sup>(1)</sup> = 185 mA	I <sub>i</sub> = 300 mA
P <sub>i</sub> <sup>(1)</sup> = 1.0 W	P <sub>i</sub> = 1.3 W
C <sub>i</sub> = 0 μF	C <sub>i</sub> = 0 μF
L <sub>i</sub> < 0.97 mH	L <sub>i</sub> < 10 μH

(1) Total for transmitter

**Type N Certification**

**N3** Certification No. GYJ12.1107X  
 Ex nA ic II CT5 Gc (-50 °C ≤ T<sub>a</sub> ≤ 70 °C)  
 Maximum Working Voltage = 42 Vdc 4-20 mA HART  
 Maximum Working Voltage = 32 Vdc Fieldbus

**K3** E3, I3, and N3 Combination

**Dust Certification**

**I3** Certification No. GYJ12.1106X  
DIP A20 Ta 90 °C ( $-20\text{ °C} \leq T_a \leq 70\text{ °C}$ )

Maximum Input Parameters:

$U_i = 30\text{ Vdc}$

$I_i = 185\text{ mA}$

$P_i = 1.0\text{ W}$

Maximum Internal Parameters:

$C_i = 0\text{ mF}$

$L_i = 0.97\text{ mH}$

**Brazilian certifications - INMETRO****Explosion proof certification**

**E2** Certificate: NCC 11.0622 X  
Remote Assembly Marking:  
Transmitter: Ex d [ia Ga] IIC T6 Gb ( $-50\text{ °C} \leq T_a \leq 70\text{ °C}$ )  
Meter Body: Ex ia IIC T6 Ga ( $-50\text{ °C} \leq T_a \leq 70\text{ °C}$ )  
Integral Assembly Marking:  
Ex d [ia] IIC T6 Ga/Gb ( $-50\text{ °C} \leq T_a \leq 70\text{ °C}$ )  
Maximum Working Voltage = 42 Vdc 4-20 mA HART  
Maximum Working Voltage = 32 Vdc FOUNDATION Fieldbus  
 $U_m = 250\text{ V}$

**Special conditions for safe use (X)**

For information related to the size of the explosion-proof joints in case of maintenance processes, the manufacturer should be consulted. The flowmeter is supplied with special screws with properties in accordance with classes A2-70 and A4-70. The painting of the housing can have more than 0.2 mm in thickness and this can cause risk of electrostatic charges. To avoid these risks, the equipment should be cleaned only with a damp and solvent-free cloth and rubbing or wiping the housing using materials with high electrical resistance should be avoided.

**Intrinsic safety**

**I2** Certificate: NCC 11.0699X  
Ex ia IIC T4 Ga ( $-60\text{ °C} \leq T_a \leq 70\text{ °C}$ ) 4-20 mA HART  
Ex ia IIC T4 Ga ( $-60\text{ °C} \leq T_a \leq 60\text{ °C}$ ) Fieldbus

**Special conditions for safe use (X)**

When the equipment is supplied with the protector of transient 90 V, the equipment is not capable of withstanding the dielectric strength test of 500 V. This must be considered in the installation. The meter housing can be made of aluminum. In spite of the external paint, care must be taken during the installation to protect it from impact or friction when it is in EPL Ga field (Zone 0). Moreover, the painting can be a dangerous source of electrostatic charges. Due to this, the equipment housing should only be cleaned with a damp cloth. During the installation, special precautions must be taken, considering the effects from the temperature of the process to ensure that the temperature marked for the housing is not exceeded.

**Japanese Certifications (TIIS)****Flameproof Certification**

**E4** Transmitter - Ex d [ia] T6

Remote Sensor - Ex ia IIC T6

Certificate	Description
TC17816	8800D with display, without MTA option
TC17817	8800D without display, without MTA option
TC18474	8800D with display, with MTA option
TC18475	8800D without display, with MTA option

# Dimensional Drawings

Figure 2. Flanged-Style Flowmeter Dimensional Drawings (1/2-through 12-in./15 through 300 mm Line Sizes)

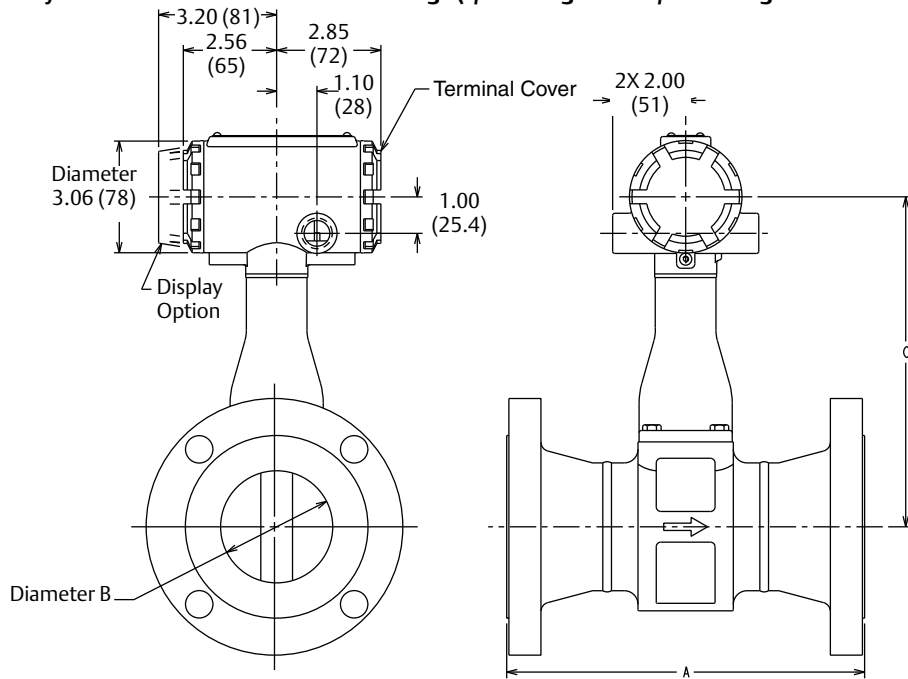
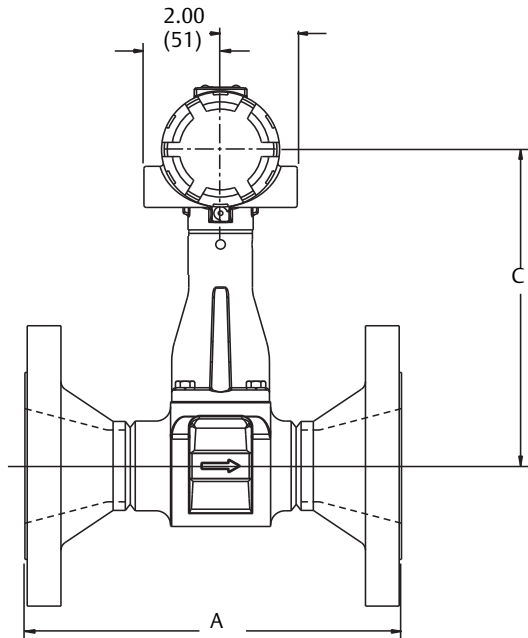

Diagram illustrated without MTA Option



**NOTE**  
Dimensions are in inches (millimeters)

Diagram illustrated with MTA Option

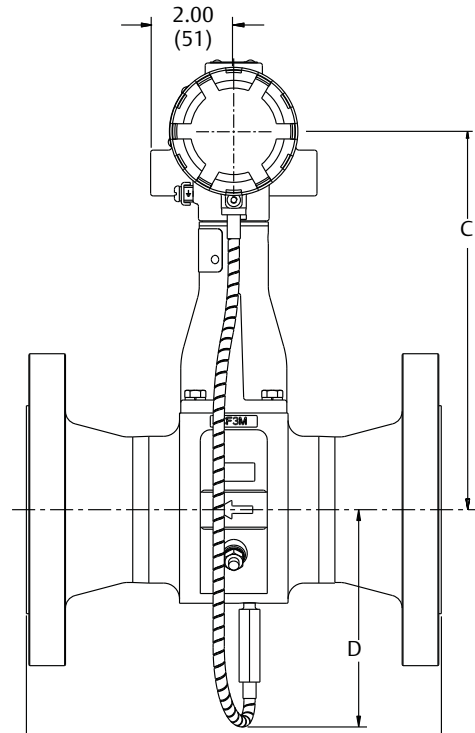

Table 21. Flanged-Style Flowmeter (1/2-through 2-in./15 through 50 mm Line Sizes)

Nominal Size Inch (mm)	Flange Rating	Face-to-face A Inch (mm)	A-ASME RTJ Inch (mm)	Diameter B Inch (mm)	C Inch (mm)	D Inch (mm)	Weight lb (kg)
1/2 (15)	Class 150	6.8 (173)	–	0.54 (13,7)	7.6 (193)		9.1 (4,1)
	Class 300	7.2 (183)	7.7 (196)	0.54 (13,7)	7.6 (193)		10.4 (4,7)
	Class 600	7.7 (196)	7.7 (196)	0.54 (13,7)	7.6 (193)		10.8 (4,9)
	Class 900	8.3 (196)	8.3 (196)	0.54 (13,7)	7.6 (193)		15.6 (7,1)
	PN 16/40	6.1 (155)	–	0.54 (13,7)	7.6 (193)		10.4 (4,7)
	PN 100	6.6 (168)	–	0.54 (13,7)	7.6 (193)		12.4 (5,6)
1 (25)	JIS 10K/20K	6.3 (160)	–	0.54 (13,7)	7.6 (193)		10.2 (4,6)
	JIS 40K	7.3 (185)	–	0.54 (13,7)	7.6 (193)		13.7 (6,2)
	Class 150	7.5 (191)	8.0 (203)	0.95 (24,1)	7.7 (196)		12.3 (5,6)
	Class 300	8.0 (203)	8.5 (216)	0.95 (24,1)	7.7 (196)		15.0 (6,8)
	Class 600	8.5 (216)	8.5 (216)	0.95 (24,1)	7.7 (196)		15.8 (7,2)
	Class 900	9.4 (239)	9.4 (239)	0.95 (24,1)	7.7 (196)		24.4 (11,1)
1 1/2 (40)	Class 1500	9.4 (239)	9.4 (239)	0.95 (24,1)	7.7 (196)		24.4 (11,1)
	PN 16/40	6.3 (160)	–	0.95 (24,1)	7.7 (196)		13.6 (6,2)
	PN 100	7.7 (195)	–	0.95 (24,1)	7.7 (196)		19.6 (8,9)
	PN 160	7.7 (195)	–	0.95 (24,1)	7.7 (196)		19.6 (8,9)
	JIS 10K/20K	6.5 (165)	–	0.95 (24,1)	7.7 (196)		14.0 (6,3)
	JIS 40K	7.8 (198)	–	0.95 (24,1)	7.7 (196)		17.7 (7,9)
2 (50)	Class 150	8.2 (208)	8.7 (221)	1.49 (37,8)	8.1 (206)	4.5 (115)	17.6 (8,0)
	Class 300	8.7 (221)	9.2 (234)	1.49 (37,8)	8.1 (206)	4.5 (115)	23.0 (10,4)
	Class 600	9.3 (236)	9.3 (236)	1.49 (37,8)	8.1 (206)	4.5 (115)	25.5 (11,6)
	Class 900	10.3 (262)	10.3 (262)	1.49 (37,8)	8.1 (206)	4.5 (115)	36.3 (16,5)
	Class 1500	10.3 (262)	10.3 (262)	1.49 (37,8)	8.1 (206)	4.5 (115)	36.6 (16,6)
	PN 16/40	6.2 (157)	–	1.49 (37,8)	8.1 (206)	4.5 (115)	19.4 (8,8)
	PN 100	8.2 (208)	–	1.49 (37,8)	8.1 (206)	4.5 (115)	28.0 (12,7)
	PN 160	8.4 (213)	–	1.49 (37,8)	8.1 (206)	4.5 (115)	39.2 (17,8)
	JIS 10K/20K	7.3 (185)	–	1.49 (37,8)	8.1 (206)	4.5 (115)	18.6 (8,4)
JIS 40K	8.4 (213)	–	1.49 (37,8)	8.1 (206)	4.5 (115)	25.5 (11,6)	
2 (50)	Class 150	9.2 (234)	9.7 (246)	1.92 (48,8)	8.5 (216)	4.7 (119)	22.0 (10,0)
	Class 300	9.7 (246)	10.4 (264)	1.92 (48,8)	8.5 (216)	4.7 (119)	26.0 (11,8)
	Class 600	10.5 (267)	10.6 (269)	1.92 (48,8)	8.5 (216)	4.7 (119)	29.6 (13,4)
	Class 900	12.7 (323)	12.9 (328)	1.92 (48,8)	8.5 (216)	4.7 (119)	59.4 (26,9)
	Class 1500	12.7 (323)	12.9 (328)	1.79 (45,5)	8.5 (216)	4.7 (119)	59.4 (26,9)
	PN 16/40	8.0 (203)	–	1.92 (48,8)	8.5 (216)	4.7 (119)	23.0 (10,4)
	PN 63	9.1 (231)	–	1.92 (48,8)	8.5 (216)	4.7 (119)	30.6 (13,9)
	PN 100	9.6 (244)	–	1.92 (48,8)	8.5 (216)	4.7 (119)	36.4 (16,5)
	PN 160	10.2 (259)	–	1.92 (48,8)	8.5 (216)	4.7 (119)	38.7 (17,6)
	JIS 10K	7.7 (196)	–	1.92 (48,8)	8.5 (216)	4.7 (119)	19.5 (8,8)
	JIS 20K	8.2 (208)	–	1.92 (48,8)	8.5 (216)	4.7 (119)	20.1 (9,1)
	JIS 40K	9.8 (249)	–	1.92 (48,8)	8.5 (216)	4.7 (119)	28.3 (12,8)

**Table 22. Flanged-Style Flowmeter (3-through 6-in./80 through 150mm Line Sizes) (Refer to previous drawing)**

Nominal Size Inch (mm)	Flange Rating	Face-to-face A Inch (mm)	A ASME RTJ Inch (mm)	Diameter B Inch (mm)	C Inch (mm)	D Inch (mm)	Weight lb (kg)	
3 (80)	Class 150	9.9 (251)	10.4 (264)	2.87 (72,9)	9.1 (231)	5.3 (134)	37.2 (16,9)	
	Class 300	10.6 (269)	11.2 (284)	2.87 (72,9)	9.1 (231)	5.3 (134)	46.5 (21,1)	
	Class 600	11.4 (290)	11.5 (292)	2.87 (72,9)	9.1 (231)	5.3 (134)	52.6 (23,8)	
	Class 900	12.9 (328)	13.0 (330)	2.87 (72,9)	9.1 (231)	5.3 (134)	76,1 (34,5)	
	Class 1500	14.1 (358)	14.2 (361)	2.66 (67,6)	9.1 (231)	–	108.9 (49,4)	
	PN 16/40	8.9 (226)	–	2.87 (72,9)	9.1 (231)	5.3 (134)	36.6 (16,6)	
	PN 63	10.0 (254)	–	2.87 (72,9)	9.1 (231)	5.3 (134)	45.3 (20,6)	
	PN 100	10.5 (267)	–	2.87 (72,9)	9.1 (231)	5.3 (134)	54.7 (24,8)	
	PN 160	11.1 (282)	–	2.87 (72,9)	9.1 (231)	–	59.6 (27,0)	
	JIS 10K	7.9 (200)	–	2.87 (72,9)	9.1 (231)	5.3 (134)	28.0 (12,7)	
	JIS 20K	9.3 (235)	–	2.87 (72,9)	9.1 (231)	5.3 (134)	35.4 (16,1)	
	JIS 40K	11.0 (280)	–	2.87 (72,9)	9.1 (231)	5.3 (134)	50.3 (22,8)	
	4 (100)	Class 150	10.3 (262)	10.8 (274)	3.79 (96,3)	9.6 (244)	5.9 (149)	51.3 (23,3)
		Class 300	11.0 (279)	11.6 (295)	3.79 (96,3)	9.6 (244)	5.9 (149)	71.5 (32,4)
Class 600		12.8 (325)	12.9 (328)	3.79 (96,3)	9.6 (244)	5.9 (149)	97.5 (44,2)	
Class 900		13.8 (351)	13.9 (353)	3.79 (96,3)	9.6 (244)	5.9 (149)	120.8 (54,8)	
Class 1500		14.5 (368)	14.6 (371)	3.43 (87,1)	9.6 (244)	–	162.6 (73,8)	
PN 16		8.4 (213)	–	3.79 (96,3)	9.6 (244)	5.9 (149)	40.4 (18,3)	
PN 40		9.4 (239)	–	3.79 (96,3)	9.6 (244)	5.9 (149)	49.5 (22,4)	
PN 63		10.4 (264)	–	3.79 (96,3)	9.6 (244)	5.9 (149)	62.5 (28,3)	
PN 100		11.3 (287)	–	3.79 (96,3)	9.6 (244)	5.9 (149)	78.9 (35,8)	
PN 160		12.1 (307)	–	3.79 (96,3)	9.6 (244)	–	86.2 (39,1)	
JIS 10K		8.7 (221)	–	3.79 (96,3)	9.6 (244)	5.9 (149)	37.5 (17,0)	
JIS 20K		8.7 (221)	–	3.79 (96,3)	9.6 (244)	5.9 (149)	45,4 (20,6)	
JIS 40K		11.8 (300)	–	3.79 (96,3)	9.6 (244)	5.9 (149)	75.8 (34,4)	
6 (150)		Class 150	11.6 (295)	12.1 (307)	5.7 (144,8)	10.8 (274)	7.4 (187)	81 (37)
	Class 300	12.3 (312)	13.0 (330)	5.7 (144,8)	10.8 (274)	7.4 (187)	120 (55)	
	Class 600	14.3 (363)	14.5 (368)	5.7 (144,8)	10.8 (274)	7.4 (187)	187 (85)	
	Class 900	16.1 (409)	16.2 (411)	5.14 (130,6)	10.8 (274)	–	277.9 (126,0)	
	Class 1500	18.6 (472)	18.8 (478)	5.14 (130,6)	10.8 (274)	–	375.8 (170,4)	
	PN 16	8.9 (226)	–	5.7 (144,8)	10.8 (274)	7.4 (187)	65.6 (29,8)	
	PN 40	10.5 (267)	–	5.7 (144,8)	10.8 (274)	7.4 (187)	85.6 (38,8)	
	PN 63	12.1 (307)	–	5.7 (144,8)	10.8 (274)	7.4 (187)	129.6 (58,8)	
	PN 100	13.7 (348)	–	5.7 (144,8)	10.8 (274)	7.4 (187)	159.5 (72,4)	
	JIS 10K	10.6 (270)	–	5.7 (144,8)	10.8 (274)	7.4 (187)	69.7 (31,6)	
	JIS 20K	10.6 (270)	–	5.7 (144,8)	10.8 (274)	7.4 (187)	87.5 (39,7)	
	JIS 40K	14.2 (360)	–	5.7 (144,8)	10.8 (274)	7.4 (187)	165.8 (75,2)	

**Table 23. Flanged-Style Flowmeter (8-through 12-in./200 through 300mm Line Sizes) (Refer to previous drawing)**

Nominal Size Inch (mm)	Flange Rating	Face-to-face A Inch (mm)	A ASME RTJ Inch (mm)	Diameter B Inch (mm)	C Inch (mm)	D Inch (mm)	Weight lb (kg)	
8 (200)	Class 150	13.5 (343)	14.0 (356)	7.55 (191,8)	11.7 (297)	8.3 (210)	130.9 (59,4)	
	Class 300	14.3 (363)	14.9 (378)	7.55 (191,8)	11.7 (297)	8.3 (210)	188.0 (85,3)	
	Class 600	16.5 (419)	16.7 (424)	7.55 (191,8)	11.7 (297)	8.3 (210)	287.9 (130,6)	
	Class 900	18.8 (478)	18.9 (480)	6.62 (168,1)	11.7 (297)	–	468.5 (212,5)	
	Class 1500	22.8 (579)	23.2 (589)	6.62 (168,1)	11.7 (297)	–	641.7 (291,1)	
	PN 10	10.4 (264)	–	7.55 (191,8)	11.7 (297)	8.3 (210)	99.8 (45,3)	
	PN 16	10.4 (264)	–	7.55 (191,8)	11.7 (297)	8.3 (210)	98.7 (44,8)	
	PN 25	11.8 (300)	–	7.55 (191,8)	11.7 (297)	8.3 (210)	127.0 (57,6)	
	PN 40	12.5 (318)	–	7.55 (191,8)	11.7 (297)	8.3 (210)	145.9 (66,2)	
	PN 63	14.2 (361)	–	7.55 (191,8)	11.7 (297)	8.3 (210)	206.4 (93,6)	
	PN 100	15.8 (401)	–	7.55 (191,8)	11.7 (297)	8.3 (210)	272.0 (123,4)	
	JIS 10K	12.2 (310)	–	7.55 (191,8)	11.7 (297)	8.3 (210)	99.4 (45,1)	
	JIS 20K	12.2 (310)	–	7.55 (191,8)	11.7 (297)	8.3 (210)	123.8 (56,2)	
	JIS 40K	16.5 (420)	–	7.55 (191,8)	11.7 (297)	8.3 (210)	245.0 (111,1)	
10 (250)	Class 150	14.5 (368)	15.0 (381)	9.56 (243)	12.8 (325)	9.3 (236)	185.7 (84,3)	
	Class 300	15.8 (401)	16.4 (417)	9.56 (243)	12.8 (325)	9.3 (236)	274.2 (124,4)	
	Class 600	19.0 (483)	19.2 (488)	9.56 (243)	12.8 (325)	9.3 (236)	466.0(211,4)	
	PN 10	11.9 (302)	–	9.56 (243)	12.8 (325)	9.3 (236)	145.2 (65,9)	
	PN 16	12.0 (305)	–	9.56 (243)	12.8 (325)	9.3 (236)	150.0 (68,0)	
	PN 25	13.5 (343)	–	9.56 (243)	12.8 (325)	9.3 (236)	186.7 (84,7)	
	PN 40	14.8 (376)	–	9.56 (243)	12.8 (325)	9.3 (236)	234.9 (106,5)	
	PN 63	16.4 (417)	–	9.56 (243)	12.8 (325)	9.3 (236)	296.3 (134,4)	
	PN 100	18.9 (480)	–	9.56 (243)	12.8 (325)	9.3 (236)	433.3 (196,5)	
	JIS 10K	14.5 (368)	–	9.56 (243)	12.8 (325)	9.3 (236)	162.6 (73,7)	
	JIS 20K	14.5 (368)	–	9.56 (243)	12.8 (325)	9.3 (236)	209.9 (95,2)	
	JIS 40K	18.1 (460)	–	9.56 (243)	12.8 (325)	9.3 (236)	366.6 (166,3)	
	12 (300)	Class 150	16.8 (427)	17.3 (439)	11.38 (289)	13.7 (348)	10.1 (256)	288.6 (130,9)
		Class 300	18.0 (457)	18.6 (472)	11.38 (289)	13.7 (348)	10.1 (256)	406.8 (184,5)
Class 600		20.5 (521)	20.6 (523)	11.38 (289)	13.7 (348)	10.1 (256)	586.5 (266,0)	
PN 10		13.1 (333)	–	11.38 (289)	13.7 (348)	10.1 (256)	195.2 (88,6)	
PN 16		13.9 (353)	–	11.38 (289)	13.7 (348)	10.1 (256)	215.7 (97,8)	
PN 25		15.0 (381)	–	11.38 (289)	13.7 (348)	10.1 (256)	260.5 (118,2)	
PN 40		16.8 (427)	–	11.38 (289)	13.7 (348)	10.1 (256)	339.0 (153,8)	
PN 63		18.8 (478)	–	11.38 (289)	13.7 (348)	10.1 (256)	422.3 (191,6)	
PN 100		21.2 (538)	–	11.38 (289)	13.7 (348)	10.1 (256)	635.2 (288,1)	
JIS 10K		15.7 (399)	–	11.38 (289)	13.7 (348)	10.1 (256)	214.0 (97,1)	
JIS 20K		15.7 (399)	–	11.38 (289)	13.7 (348)	10.1 (256)	275.3 (124,9)	
JIS 40K		19.6 (498)	–	11.38 (289)	13.7 (348)	10.1 (256)	485.0 (220,0)	

Figure 3. Rosemount 8800DR Reducer Flowmeter Dimensional Drawings (1-through 12-in./25 through 300 mm Line Sizes)

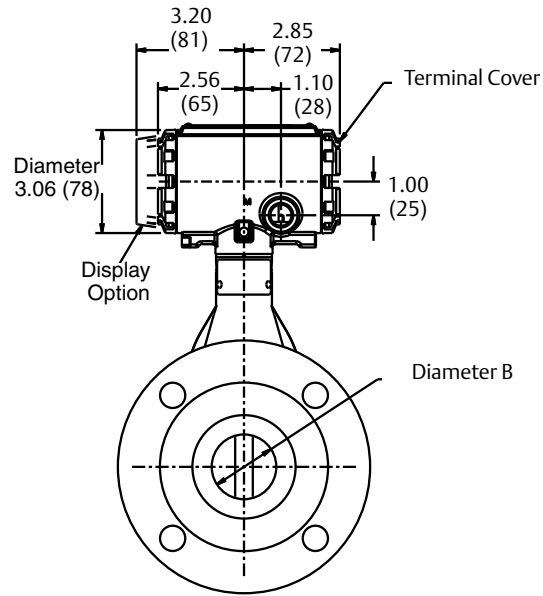



Diagram illustrated without MTA Option

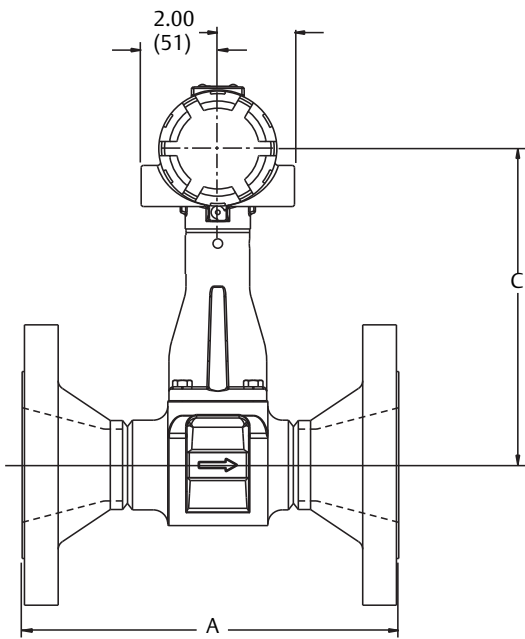
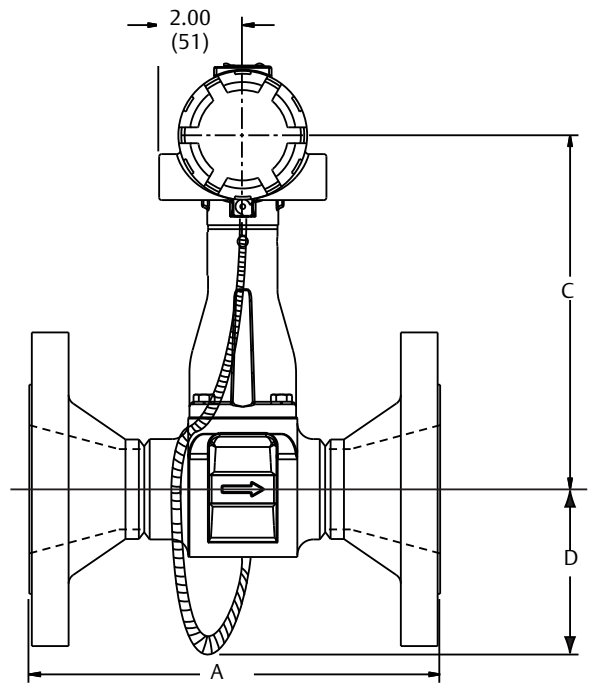

Diagram illustrated with MTA Option



**NOTE**  
Dimensions are in inches (millimeters)

Table 24. Reducer Flowmeter (1-through 3in./25 through 80 mm Line Sizes)

Nominal Size Inch (mm)	Flange Rating	Face-to-face A Inch (mm)	A-ASME RTJ Inch (mm)	Diameter B Inch (mm)	C Inch (mm)	D Inch (mm)	Weight lb (kg)
1 (25)	Class 150	7.5 (191)	8.0 (203)	0.54 (13,7)	7.6 (193)	–	11.56 (5,24)
	Class 300	8.0 (203)	8.5 (216)	0.54 (13,7)	7.6 (193)	–	14.22 (6,45)
	Class 600	8.5 (216)	8.5 (216)	0.54 (13,7)	7.6 (193)	–	15.11 (6,85)
	Class 900	9.4 (239)	9.4 (239)	0.54 (13,7)	7.6 (193)	–	20.70 (9,40)
	PN 16/40	6.2 (157)	–	0.54 (13,7)	7.6 (193)	–	12.64 (5,73)
	PN 100	7.7 (195)	–	0.54 (13,7)	7.6 (193)	–	18.44 (8,36)
1 ½ (40)	PN 160	7.7 (195)	–	0.54 (13,7)	7.6 (193)	–	18.44 (8,36)
	Class 150	8.2 (208)	8.7 (221)	0.95 (24,1)	7.7 (196)	–	15.81 (7,17)
	Class 300	8.7 (221)	9.2 (234)	0.95 (24,1)	7.7 (196)	–	21.20 (9,62)
	Class 600	9.3 (236)	9.3 (236)	0.95 (24,1)	7.7 (196)	–	23.77 (10,78)
	Class 900	10.3 (262)	10.3 (262)	0.95 (24,1)	7.7 (196)	–	34.98 (15,87)
	PN 16/40	6.9 (175)	–	0.95 (24,1)	7.7 (196)	–	17.50 (7,94)
2 (50)	PN 100	8.2 (208)	–	0.95 (24,1)	7.7 (196)	–	26.20 (11,88)
	PN 160	8.4 (213)	–	0.95 (24,1)	7.7 (196)	–	27.67 (12,55)
	Class 150	9.2 (234)	9.7 (246)	1.49 (37,8)	8.1 (206)	–	22.61 (10,26)
	Class 300	9.7 (246)	10.4 (264)	1.49 (37,8)	8.1 (206)	–	26.76 (12,14)
	Class 600	10.5 (267)	10.6 (269)	1.49 (37,8)	8.1 (206)	–	30.59 (13,88)
	Class 900	12.7 (323)	12.9 (328)	1.49 (37,8)	8.1 (206)	–	60.76 (27,56)
3 (80)	PN 16/40	8.0 (203)	–	1.49 (37,8)	8.1 (206)	–	23.52 (10,67)
	PN 63	9.1 (231)	–	1.49 (37,8)	8.1 (206)	–	31.28 (14,19)
	PN 100	9.6 (244)	–	1.49 (37,8)	8.1 (206)	–	37.25 (16,90)
	PN 160	10.2 (259)	–	1.49 (37,8)	8.1 (206)	–	39.64 (17,98)
	Class 150	9.9 (251)	10.4 (264)	1.92 (48,8)	8.5 (216)	4.5 (115)	33.15 (15,04)
	Class 300	10.6 (269)	11.2 (284)	1.92 (48,8)	8.5 (216)	4.5 (115)	42.66 (19,35)
3 (80)	Class 600	11.4 (290)	11.5 (292)	1.92 (48,8)	8.5 (216)	4.5 (115)	49.46 (22,43)
	Class 900	12.9 (328)	13.0 (330)	1.92 (48,8)	8.5 (216)	4.5 (115)	73.28 (33,24)
	PN 16/40	8.9 (226)	–	1.92 (48,8)	8.5 (216)	4.5 (115)	32.89 (14,95)
	PN 63	10.0 (254)	–	1.92 (48,8)	8.5 (216)	4.5 (115)	42.04 (19,11)
	PN 100	10.5 (267)	–	1.92 (48,8)	8.5 (216)	4.5 (115)	51.80 (23,54)
	PN 160	11.1 (282)	–	1.92 (48,8)	8.5 (216)	4.5 (115)	57.53 (26,15)

Table 25. Reducer Flowmeter (4-through 12-in./100 through 300mm Line Sizes) (Refer to previous drawing)

Nominal Size Inch (mm)	Flange Rating	Face-to-face A Inch (mm)	A ASME RTJ Inch (mm)	Diameter B Inch (mm)	C Inch (mm)	D Inch (mm)	Weight lb (kg)
4 (100)	Class 150	10.3 (262)	10.8 (274)	2.87 (72,9)	9.1 (231)	5.3 (134)	46.33 (21,01)
	Class 300	11.0 (279)	11.6 (295)	2.87 (72,9)	9.1 (231)	5.3 (134)	67.04 (30,41)
	Class 600	12.8 (325)	12.9 (328)	2.87 (72,9)	9.1 (231)	5.3 (134)	94.26 (42,76)
	Class 900	13.8 (351)	13.9 (353)	2.87 (72,9)	9.1 (231)	5.3 (134)	118.04 (53,54)
	PN 16	8.4 (213)	–	2.87 (72,9)	9.1 (231)	5.3 (134)	36.36 (16,49)
	PN 40	9.4 (239)	–	2.87 (72,9)	9.1 (231)	5.3 (134)	45.89 (20,81)
	PN 63	10.4 (264)	–	2.87 (72,9)	9.1 (231)	5.3 (134)	59.72 (27,09)
6 (150)	Class 150	11.6 (295)	12.1 (307)	3.79 (96,3)	9.6 (244)	5.9 (149)	70.27 (31,87)
	Class 300	12.3 (312)	13.0 (330)	3.79 (96,3)	9.6 (244)	5.9 (149)	113.09 (51,30)
	Class 600	14.3 (363)	14.5 (368)	3.79 (96,3)	9.6 (244)	5.9 (149)	185.13 (83,97)
	Class 900	16.1 (409)	16.2 (411)	3.79 (96,3)	9.6 (244)	5.9 (149)	246.33 (111,73)
	PN 16	8.9 (226)	–	3.79 (96,3)	9.6 (244)	5.9 (149)	59.20 (26,85)
	PN 40	10.5 (267)	–	3.79 (96,3)	9.6 (244)	5.9 (149)	81.94 (37,17)
	PN 63	12.1 (307)	–	3.79 (96,3)	9.6 (244)	5.9 (149)	125.36 (56,86)
8 (200)	Class 150	13.5 (343)	14.0 (356)	5.70 (144,8)	10.8 (274)	7.4 (187)	123.39 (56,09)
	Class 300	14.3 (363)	14.9 (378)	5.70 (144,8)	10.8 (274)	7.4 (187)	185.68 (84,40)
	Class 600	16.5 (419)	16.7 (424)	5.70 (144,8)	10.8 (274)	7.4 (187)	295.22 (134,19)
	PN 10	10.4 (264)	–	5.70 (144,8)	10.8 (274)	7.4 (187)	90.78 (41,26)
	PN 16	10.4 (264)	–	5.70 (144,8)	10.8 (274)	7.4 (187)	90.78 (41,26)
	PN 25	11.8 (300)	–	5.70 (144,8)	10.8 (274)	7.4 (187)	123.94 (56,34)
	PN 40	12.5 (318)	–	5.70 (144,8)	10.8 (274)	7.4 (187)	144.88 (65,85)
10 (250)	Class 150	14.5 (368)	15.0 (381)	7.55 (191,8)	11.7 (297)	8.3 (210)	170.55 (77,52)
	Class 300	15.8 (401)	16.4 (417)	7.55 (191,8)	11.7 (297)	8.3 (210)	269.50 (122,50)
	Class 600	19.0 (483)	19.2 (488)	7.55 (191,8)	11.7 (297)	8.3 (210)	477.06 (216,84)
	PN 10	11.9 (302)	–	7.55 (191,8)	11.7 (297)	8.3 (210)	126.77 (57,62)
	PN 16	12.0 (305)	–	7.55 (191,8)	11.7 (297)	8.3 (210)	136.68 (62,13)
	PN 25	13.5 (343)	–	7.55 (191,8)	11.7 (297)	8.3 (210)	178.81 (81,28)
	PN 40	14.8 (376)	–	7.55 (191,8)	11.7 (297)	8.3 (210)	233.38 (106,08)
12 (300)	Class 150	16.8 (427)	17.3 (439)	9.56 (242,8)	12.8 (325)	9.3 (236)	270.05 (122,75)
	Class 300	18.0 (457)	18.6 (472)	9.56 (242,8)	12.8 (325)	9.3 (236)	400.25 (181,93)
	Class 600	20.5 (521)	20.6 (523)	9.56 (242,8)	12.8 (325)	9.3 (236)	597.96 (271,80)
	PN 10	13.1 (333)	–	9.56 (242,8)	12.8 (325)	9.3 (236)	176.36 (80,16)
	PN 16	13.9 (353)	–	9.56 (242,8)	12.8 (325)	9.3 (236)	199.86 (90,85)
	PN 25	15.0 (381)	–	9.56 (242,8)	12.8 (325)	9.3 (236)	250.52 (113,87)
	PN 40	16.8 (427)	–	9.56 (242,8)	12.8 (325)	9.3 (236)	337.99 (153,63)
12 (300)	PN 63	18.8 (478)	–	9.56 (242,8)	12.8 (325)	9.3 (236)	432.28 (196,49)
	PN 100	21.2 (538)	–	9.56 (242,8)	12.8 (325)	9.3 (236)	660.14 (300,06)

Figure 4. Wafer-Style Dimensional Drawings (<sup>1</sup>/<sub>2</sub>-through 8-in./15 through 200 mm Line Sizes)

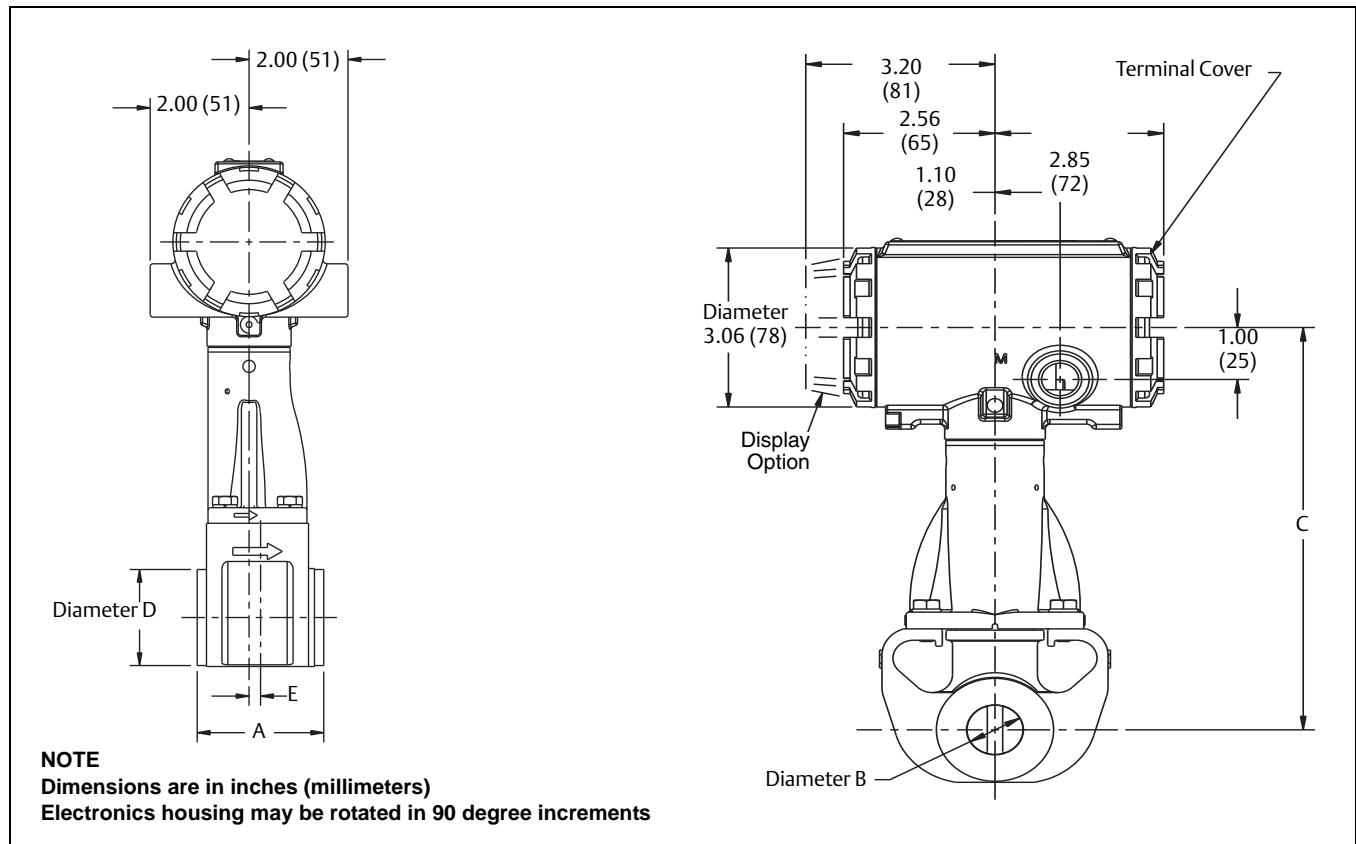

Table 26. Rosemount 8800D Wafer-Style Meter

Nominal Size Inch (mm)	Face-to-face A Inch (mm)	Diameter B Inch (mm)	C Inch (mm)	Diameter D Inch (mm)	E Inch (mm)	Weight lb (kg) <sup>(1)</sup>
½ (15)	2.56 (65)	0.54 (13,7)	7.63 (194)	1.38 (35,1)	0.23 (5,9)	7.3 (3,3)
1 (25)	2.56 (65)	0.95 (24,1)	7.74 (197)	1.98 (50,3)	0.23 (5,9)	7.4 (3,4)
1½ (40)	2.56 (65)	1.49 (37,8)	8.14 (207)	2.87 (72,9)	0.18 (4,6)	10.0 (4,5)
2 (50)	2.56 (65)	1.92 (49)	8.85 (225)	3.86 (98)	0.12 (3)	10.6 (4,8)
3 (80)	2.56 (65)	2.87 (73)	9.62 (244)	5.00 (127)	0.25 (6)	13.6 (6,2)
4 (100)	3.42 (87)	3.79 (96)	10.48 (266)	6.20 (158)	0.44 (11)	21.4 (9,7)
6 (150)	4.99 (127)	5.70 (145)	10.29 (261)	8.50 (216)	.30 (7,6)	35.7 (16,2)
8 (200)	6.60 (168)	7.55 (192)	11.22 (285)	10.62 (270)	.70 (17,8)	62.3 (28,3)

(1) Add 0.2 lb (0,1 kg) for display option.

Figure 5. Vortex Dual-Sensor Style Flowmeter Dimensional Drawings (1/2-in (15 mm) through 4-in. (100 mm) line sizes)

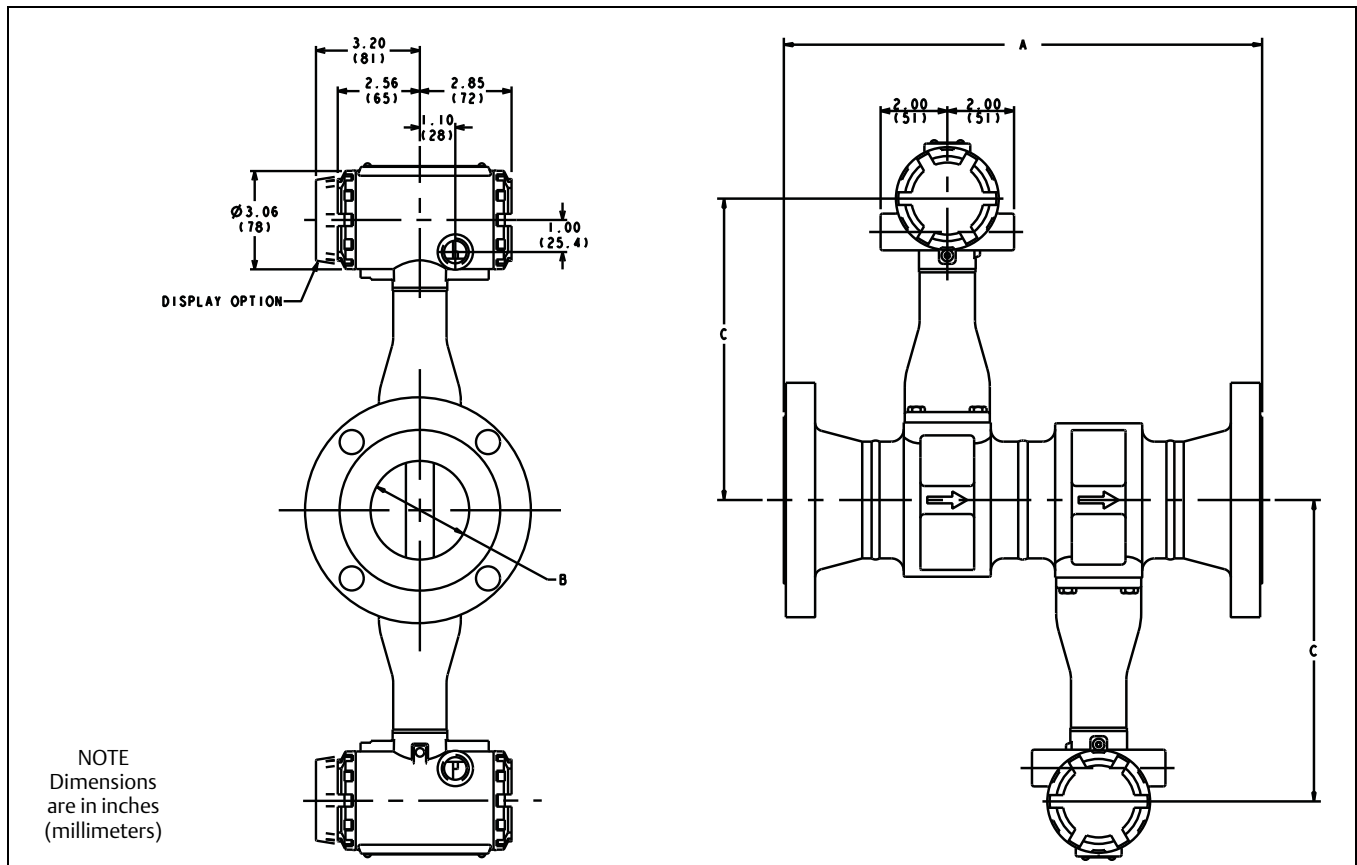

Figure 6. Vortex Dual-Sensor Style Flowmeter Dimensional Drawings (6-in. (150 mm) through 12-in. (300 mm) line sizes)

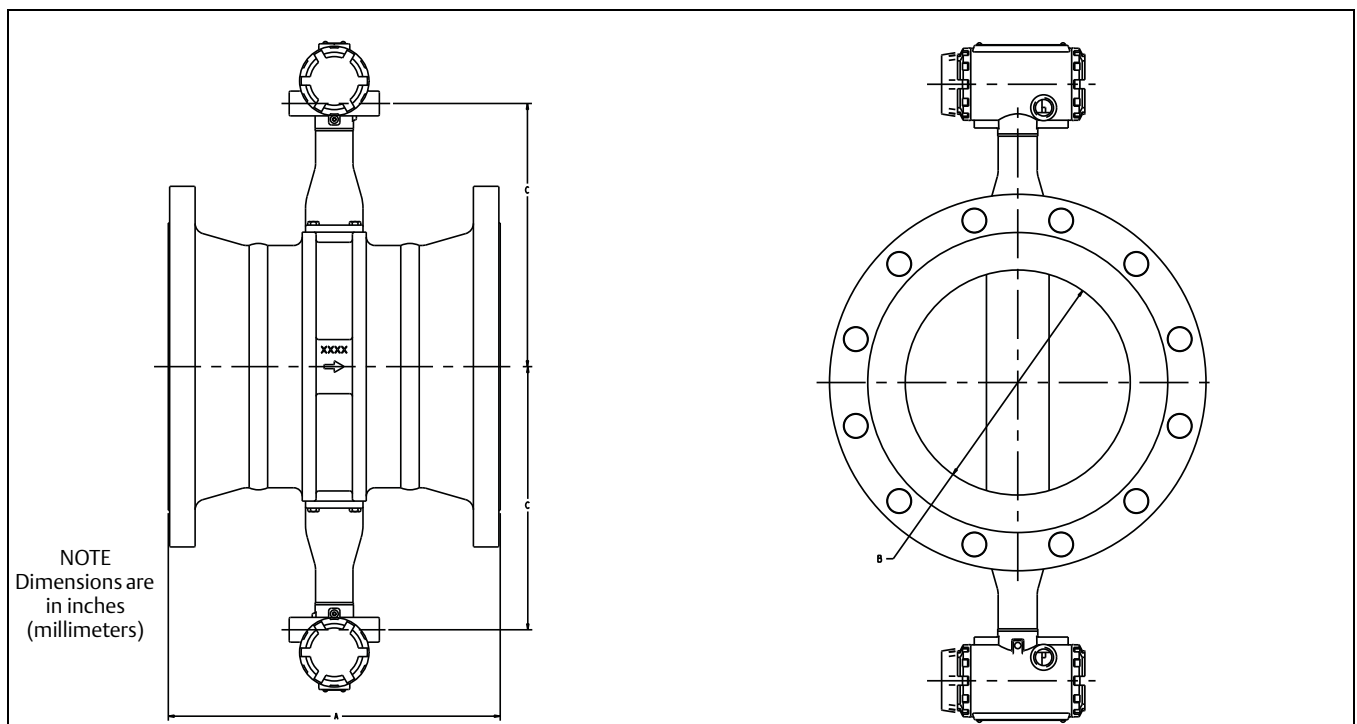

Table 27. Vortex Dual-Sensor Style Flowmeter (1/2-through 3-in./15 through 80 mm Line Sizes)

Nominal Size Inch (mm)	Flange Rating	Face-to-face A Inch (mm)	A ASME RTJ Inch (mm)	Diameter B Inch (mm)	C Inch (mm)	Weight lb (kg)
1/2 (15)	Class 150	11.9 (302)	–	0.54 (13,7)	7.6 (193)	16.2 (7,4)
	Class 300	12.3 (312)	12.7 (323)	0.54 (13,7)	7.6 (193)	17.4 (7,9)
	Class 600	12.8 (325)	12.7 (323)	0.54 (13,7)	7.6 (193)	17.9 (8,1)
	Class 900	13.4 (340)	13.4 (340)	0.54 (13,7)	7.6 (193)	22.4 (10,2)
	PN 16/40	11.2 (284)	–	0.54 (13,7)	7.6 (193)	17.2 (7,8)
	PN 100	11.8 (300)	–	0.54 (13,7)	7.6 (193)	19.2 (8,7)
1 (25)	JIS 10K/20K	11.4 (290)	–	0.54 (13,7)	7.6 (193)	17.1 (7,8)
	JIS 40K	12.4 (315)	–	0.54 (13,7)	7.6 (193)	20.6 (9,3)
	Class 150	15.0 (384)	15.6 (396)	0.95 (24,1)	7.7 (196)	20.7 (9,4)
	Class 300	15.6 (396)	16.1 (409)	0.95 (24,1)	7.7 (196)	23.3 (10,6)
	Class 600	16.1 (409)	16.1 (409)	0.95 (24,1)	7.7 (196)	24.2 (11,1)
	Class 900	16.9 (429)	16.9 (429)	0.95 (24,1)	7.7 (196)	32.8 (14,9)
1 1/2 (40)	Class 1500	16.9 (429)	16.9 (429)	0.95 (24,1)	7.7 (196)	32.8 (14,9)
	PN 16/40	13.9 (353)	–	0.95 (24,1)	7.7 (196)	21.9 (9,9)
	PN 100	15.3 (389)	–	0.95 (24,1)	7.7 (196)	28.0 (12,7)
	PN 160	15.3 (389)	–	0.95 (24,1)	7.7 (196)	28.0 (12,7)
	JIS 10K/20K	14.1 (358)	–	0.95 (24,1)	7.7 (196)	22.3 (10,1)
	JIS 40K	15.5 (394)	–	0.95 (24,1)	7.7 (196)	26.0 (11,8)
2 (50)	Class 150	11.3 (287)	11.8 (300)	1.49 (37,8)	8.1 (206)	27.0 (12,3)
	Class 300	11.8 (300)	12.3 (312)	1.49 (37,8)	8.1 (206)	32.4 (14,7)
	Class 600	12.4 (315)	12.4 (315)	1.49 (37,8)	8.1 (206)	34.8 (15,8)
	Class 900	13.4 (340)	13.4 (340)	1.49 (37,8)	8.1 (206)	45.9 (20,8)
	Class 1500	13.4 (340)	13.4 (340)	1.49 (37,8)	8.1 (206)	45.9 (20,8)
	PN 16/40	9.9 (251)	–	1.49 (37,8)	8.1 (206)	28.7 (13,0)
3 (80)	PN 100	11.3 (287)	–	1.49 (37,8)	8.1 (206)	37.4 (17,0)
	PN 160	11.4 (290)	–	1.49 (37,8)	8.1 (206)	38.8 (17,6)
	JIS 10K/20K	10.3 (262)	–	1.49 (37,8)	8.1 (206)	27.9 (12,6)
	JIS 40K	11.5 (292)	–	1.49 (37,8)	8.1 (206)	34.9 (15,8)
	Class 150	13.0 (330)	13.5 (343)	1.92 (48,8)	8.5 (216)	31.9 (14,5)
	Class 300	13.5 (343)	14.0 (356)	1.92 (48,8)	8.5 (216)	35.7 (16,2)
1 1/2 (40)	Class 600	14.3 (363)	14.3 (363)	1.92 (48,8)	8.5 (216)	39.4 (17,9)
	Class 900	16.5 (419)	16.7 (424)	1.92 (48,8)	8.5 (216)	69.1 (31,4)
	Class 1500	15.6 (396)	15.7 (399)	1.67 (42,4)	8.5 (216)	72.4 (32,9)
	PN 16/40	11.8 (300)	–	1.92 (48,8)	8.5 (216)	32.8 (14,9)
	PN 63	12.9 (328)	–	1.92 (48,8)	8.5 (216)	40.4 (18,3)
	PN 100	13.4 (340)	–	1.92 (48,8)	8.5 (216)	46.2 (20,9)
2 (50)	PN 160	13.9 (353)	–	1.92 (48,8)	8.5 (216)	48.4 (21,9)
	JIS 10K	11.5 (292)	–	1.92 (48,8)	8.5 (216)	29.1 (13,2)
	JIS 20K	12.0 (305)	–	1.92 (48,8)	8.5 (216)	30.0 (13,6)
	JIS 40K	13.6 (345)	–	1.92 (48,8)	8.5 (216)	38.1 (17,3)
	Class 150	14.3 (363)	14.8 (376)	2.87 (72,9)	9.1 (231)	50.6 (23,0)
	Class 300	15.0 (381)	15.7 (399)	2.87 (72,9)	9.1 (231)	59.9 (27,2)
3 (80)	Class 600	15.8 (401)	15.8 (401)	2.87 (72,9)	9.1 (231)	65.9 (29,9)
	Class 900	17.3 (439)	17.4 (442)	2.87 (72,9)	9.1 (231)	88.4 (40,8)
	Class 1500	18.5 (470)	18.6 (472)	2.60 (66,0)	9.1 (232)	123.8 (56,2)
	PN 16/40	13.4 (340)	–	2.87 (72,9)	9.1 (231)	50.0 (22,7)
	PN 63	14.5 (367)	–	2.87 (72,9)	9.1 (231)	58.7 (26,6)
	PN 100	14.9 (378)	–	2.87 (72,9)	9.1 (231)	68.0 (30,9)
3 (80)	PN 160	15.6 (396)	–	2.87 (72,9)	9.1 (231)	73.4 (33,3)
	JIS 10K	12.3 (312)	–	2.87 (72,9)	9.1 (231)	41.4 (18,8)
	JIS 20K	13.7 (348)	–	2.87 (72,9)	9.1 (231)	48.8 (22,1)
	JIS 40K	15.5 (394)	–	2.87 (72,9)	9.1 (231)	63.7 (28,9)

**Table 28. Vortex Dual-Sensor Style Flowmeter (4- through 12-in./100 through 300 mm Line Sizes)**

Nominal Size Inch (mm)	Flange Rating	Face-to-face A Inch (mm)	A ASME RTJ Inch (mm)	Diameter B Inch (mm)	C Inch (mm)	Weight lb (kg)	
4 (100)	Class 150	15.2 (386)	15.7 (399)	3.79 (96,3)	9.6 (244)	69.7 (31,6)	
	Class 300	16.0 (406)	16.6 (422)	3.79 (96,3)	9.6 (244)	88.9 (40,8)	
	Class 600	17.7 (450)	17.7 (450)	3.79 (96,3)	9.6 (244)	116 (52,5)	
	Class 900	18.7 (475)	18.9 (480)	3.79 (96,3)	9.6 (244)	139 (63,1)	
	Class 1500	20.0 (509)	20.2 (512)	3.40 (86,4)	9.6 (244)	184 (83,3)	
	PN 16	13.3 (338)	–	3.79 (96,3)	9.6 (244)	58.7 (26,6)	
	PN 40	14.4 (366)	–	3.79 (96,3)	9.6 (244)	67.8 (30,8)	
	PN 63	15.4 (391)	–	3.79 (96,3)	9.6 (244)	80.8 (36,7)	
	PN 100	16.3 (414)	–	3.79 (96,3)	9.6 (244)	97.2 (44,1)	
	PN 160	17.1 (434)	–	3.79 (96,3)	9.6 (244)	104 (47,4)	
	JIS 10K	13.6 (345)	–	3.79 (96,3)	9.6 (244)	55.8 (25,3)	
	JIS 20K	13.6 (345)	–	3.79 (96,3)	9.6 (244)	63.8 (28,9)	
	JIS 40K	16.8 (427)	–	3.79 (96,3)	9.6 (244)	94.2 (42,7)	
	6 (150)	Class 150	11.6 (295)	12.1 (307)	5.7 (144,8)	10.8 (274)	85 (39)
		Class 300	12.3 (312)	13.0 (330)	5.7 (144,8)	10.8 (274)	124 (57)
Class 600		14.3 (363)	14.4 (366)	5.7 (144,8)	10.8 (274)	191 (87)	
Class 900		16.1 (409)	16.2 (411)	5.14 (130,6)	10.8 (274)	282 (198)	
Class 1500		18.6 (472)	18.8 (478)	5.14 (130,6)	10.8 (274)	380 (173)	
PN 16		8.9 (226)	–	5.7 (144,8)	10.8 (274)	70 (32)	
PN 40		10.5 (267)	–	5.7 (144,8)	10.8 (274)	90 (41)	
PN 63		12.1 (307)	–	5.7 (144,8)	10.8 (274)	134 (61)	
PN 100		13.6 (345)	–	5.7 (144,8)	10.8 (274)	164 (75)	
JIS 10K		10.6 (269)	–	5.7 (144,8)	10.8 (274)	74 (34)	
JIS 20K		10.6 (269)	–	5.7 (144,8)	10.8 (274)	92 (42)	
JIS 40K		14.2 (361)	–	5.7 (144,8)	10.8 (274)	170 (77)	
8 (200)		Class 150	13.5 (343)	14.0 (356)	7.55 (191,8)	11.7 (297)	135.2 (61,3)
		Class 300	14.3 (363)	14.9 (378)	7.55 (191,8)	11.7 (297)	192.3 (87,2)
		Class 600	16.5 (419)	16.7 (424)	7.55 (191,8)	11.7 (297)	292.2 (132,5)
	Class 900	18.8 (478)	18.9 (480)	6.62 (168,1)	11.7 (297)	472.8 (214,5)	
	Class 1500	22.8 (580)	23.2 (589)	6.62 (168,1)	11.7 (297)	646.0 (293,0)	
	PN 10	10.4 (264)	–	7.55 (191,8)	11.7 (297)	104.1 (47,2)	
	PN 16	10.4 (264)	–	7.55 (191,8)	11.7 (297)	103.0 (46,7)	
	PN 25	11.8 (300)	–	7.55 (191,8)	11.7 (297)	131.3 (59,6)	
	PN 40	12.5 (318)	–	7.55 (191,8)	11.7 (297)	150.2 (68,1)	
	PN 63	14.2 (361)	–	7.55 (191,8)	11.7 (297)	210.7 (95,6)	
	PN 100	15.8 (401)	–	7.55 (191,8)	11.7 (297)	276.3 (125,3)	
	JIS 10K	12.2 (310)	–	7.55 (191,8)	11.7 (297)	103.7 (47,0)	
	JIS 20K	12.2 (310)	–	7.55 (191,8)	11.7 (297)	128.1 (58,1)	
	JIS 40K	16.5 (419)	–	7.55 (191,8)	11.7 (297)	370.9 (168,2)	
	10 (250)	Class 150	14.5 (368)	15.1 (384)	9.56 (243)	12.8 (325)	190.0 (86,2)
Class 300		15.8 (401)	16.4 (417)	9.56 (243)	12.8 (325)	278.5 (126,3)	
Class 600		19.0 (483)	19.2 (488)	9.56 (243)	12.8 (325)	470.3 (213,3)	
PN 10		11.9 (302)	–	9.56 (243)	12.8 (325)	149.5 (67,8)	
PN 16		12.0 (305)	–	9.56 (243)	12.8 (325)	154.3 (70,0)	
PN 25		13.5 (343)	–	9.56 (243)	12.8 (325)	191.0 (86,6)	
PN 40		14.8 (376)	–	9.56 (243)	12.8 (325)	239.2 (108,5)	
PN 63		16.4 (417)	–	9.56 (243)	12.8 (325)	300.6 (136,3)	
PN 100		18.9 (480)	–	9.56 (243)	12.8 (325)	437.6 (198,5)	
JIS 10K		14.5 (368)	–	9.56 (243)	12.8 (325)	166.9 (75,7)	
JIS 20K		14.5 (368)	–	9.56 (243)	12.8 (325)	214.2 (97,2)	
JIS 40K		18.1 (460)	–	9.56 (243)	12.8 (325)	370.9 (168,2)	
12 (300)		Class 150	16.8 (427)	17.3 (439)	11.38 (289)	13.7 (348)	292.9 (132,9)
		Class 300	18.0 (457)	18.7 (475)	11.38 (289)	13.7 (348)	411.1 (186,5)
		Class 600	20.5 (521)	20.6 (523)	11.38 (289)	13.7 (348)	590.8 (268,0)
	PN 10	13.1 (333)	–	11.38 (289)	13.7 (348)	199.5 (90,5)	
	PN 16	13.9 (353)	–	11.38 (289)	13.7 (348)	220.0 (99,8)	
	PN 25	15.0 (381)	–	11.38 (289)	13.7 (348)	264.8 (120,1)	
	PN 40	16.8 (427)	–	11.38 (289)	13.7 (348)	343.3 (155,7)	
	PN 63	18.8 (478)	–	11.38 (289)	13.7 (348)	426.6 (193,5)	
	PN 100	21.2 (538)	–	11.38 (289)	13.7 (348)	639.5 (290,1)	
	JIS 10K	15.7 (399)	–	11.38 (289)	13.7 (348)	218.3 (99,0)	
	JIS 20K	15.7 (399)	–	11.38 (289)	13.7 (348)	279.6 (126,8)	
	JIS 40K	19.6 (498)	–	11.38 (289)	13.7 (348)	489.2 (221,9)	



Figure 7. Vortex weld-end style flowmeter dimensional drawings (1/2 - 12-in. (15 - 300 mm) line sizes)

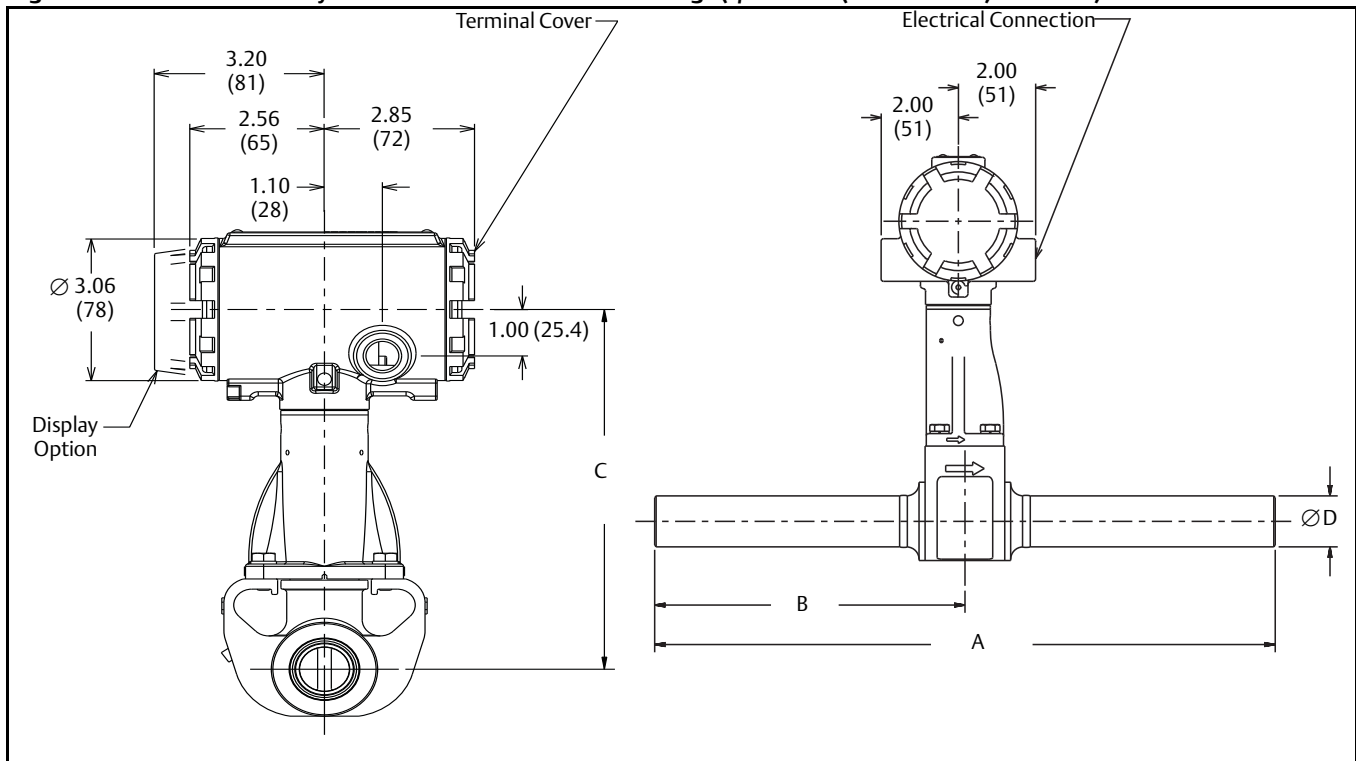

Table 29. Vortex weld-end style flowmeter (1/2 - 12-in. (15 - 300 mm) line sizes)

Nominal Size in. (mm)	Pipe Schedule	A ± 0.10 in. (2,5 mm)	B ± 0.05 in. (2,5 mm)	C ± 0.20 in. (5,1 mm)	Diameter D ± 0.031 in. (0,79 mm)	Weight lb (kg)
0.5 DN15	All	16.0 (406)	8.0 (203)	7.63 (194)	.840 (21,34)	8.1 (3,7)
1 DN25	All	16.0 (406)	8.0 (203)	7.74 (197)	1.315 (33,40)	9.9 (4,5)
1.5 DN40	All	16.0 (406)	8.0 (203)	8.14 (207)	1.900 (48,26)	13.3 (6,1)
2 DN50	10S 40S 80S	16.0 (406)	8.0 (203)	8.49 (216)	2.375 (60,33)	14.9 (6,8)
	160					18.3 (8,3)
3 DN80	10S 40S 80S	16.0 (406)	8.0 (203)	9.05 (230)	3.500 (88,90)	23.5 (10,7)
	160					29.1 (13,2)
4 DN100	10S 40S 80S	16.0 (406)	8.0 (203)	9.60 (244)	4.500 (114,30)	32.4 (14,7)
	160					42.7 (19,4)
6 DN150	10S 40S 80S	18.0 (457)	9.0 (229)	10.80 (274)	6.625 (168)	60.4 (27,5)
	160					86.8 (39,5)
8 DN200	10S 40S 80S	18.0 (457)	9.0 (229)	11.70 (297)	8.625 (219)	88.6 (40,3)
	160					144.2 (65,6)
10 DN250	All	20 (508)	10 (250)	12.80 (325)	10.750 (273)	135 (61,4)
12 DN300	All	20 (508)	10 (250)	13.70 (348)	12.750 (324)	185 (84,1)

Figure 8. Dimensional Drawings for Remote Mount Transmitters

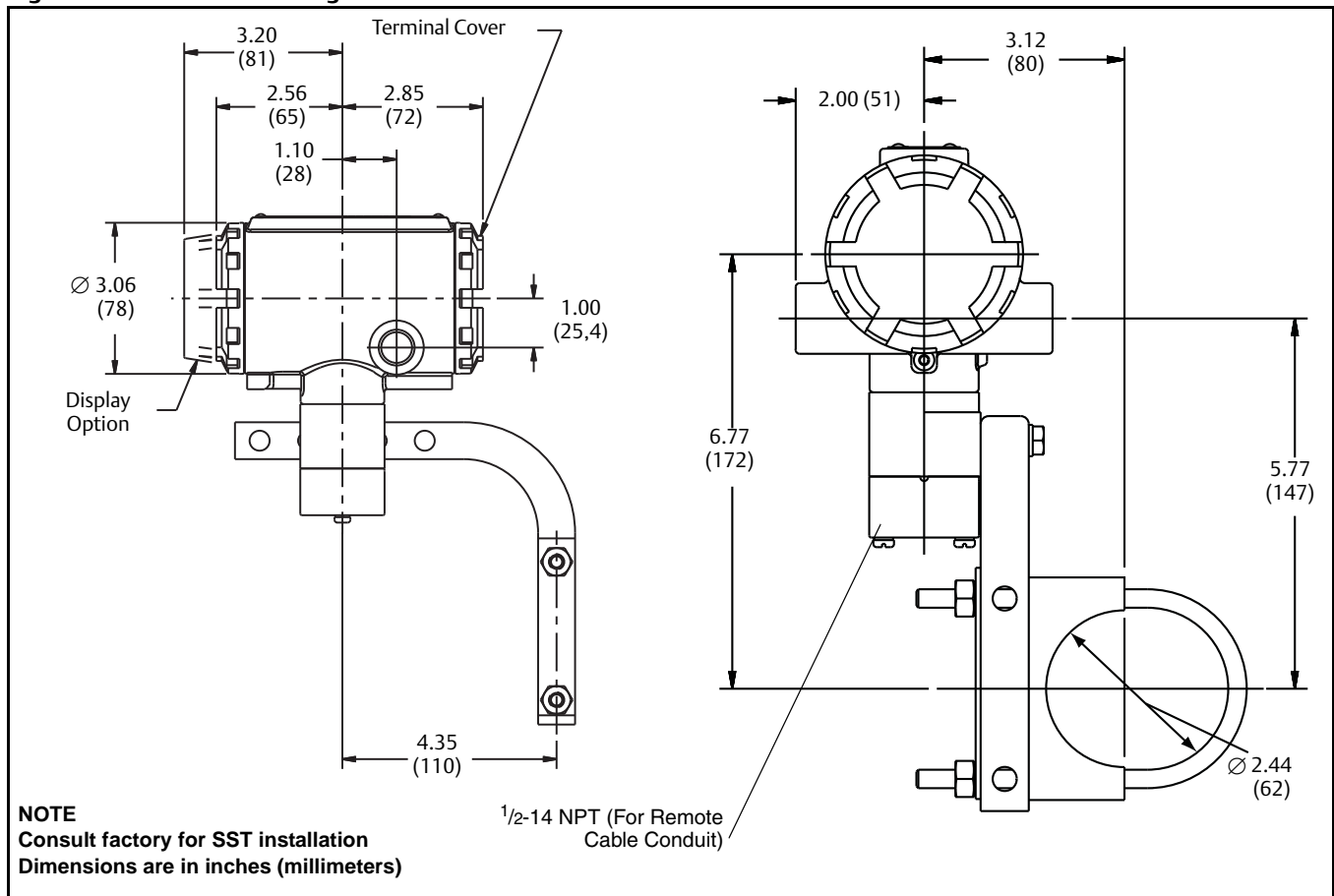

Figure 9. Dimensional Drawings for Remote Mount Wafer-Style Flowmeters ( $1/2$ -through 8-in./15 through 200 mm Line Sizes)

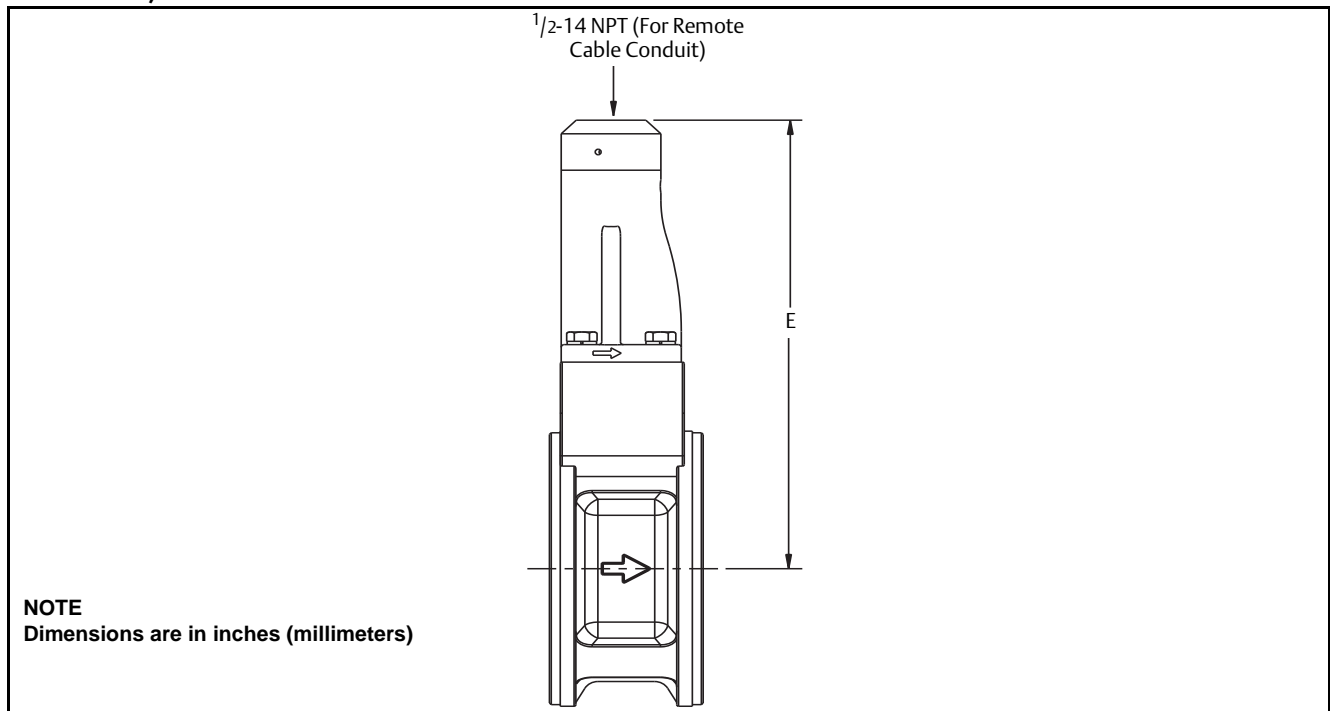
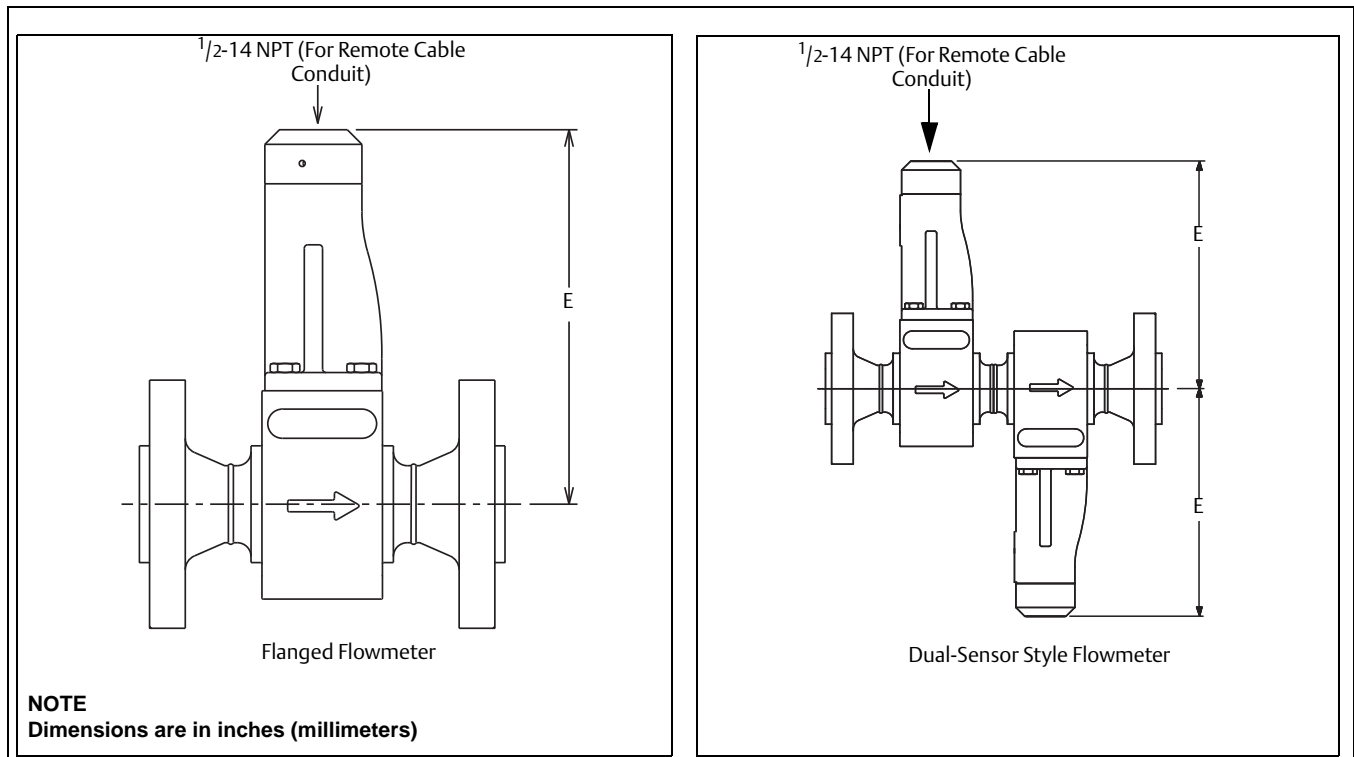

Table 30. Rosemount 8800D Wafer-Style Meter

Nominal Size in. (mm)	E Wafer Style in. (mm)
$1/2$ (15)	6.4 (163)
1 (25)	6.5 (165)
$1\frac{1}{2}$ (40)	6.9 (175)
2 (50)	7.6 (193)
3 (80)	8.3 (211)
4 (100)	9.2 (234)
6 (150)	9.5 (241)
8 (200)	10.4 (264)

**Figure 10. Dimensional Drawings for Flanged-and Dual Sensor Flanged-Style Remote Mount Flowmeters (1/2-through 12-in./15 through 300 mm Line Sizes)**



**Table 31. Remote Mount, Flanged-and Dual Sensor Flowmeter Dimensions**

Nominal Size in. (mm)	E Flange Style in. (mm)
1/2 (15)	6.4 (162)
1 (25)	6.5 (165)
1 1/2 (40)	6.8 (173)
2 (50)	7.2 (183)
3 (80)	7.8 (198)
4 (100)	8.3 (211)
6 (150)	9.5 (241)
8 (200)	10.4 (264)
10 (250)	11.4 (290)
12 (300)	12.3 (313)

**Emerson Process Management**

Rosemount Inc.  
8200 Market Boulevard  
Chanhassen, MN 55317 USA  
T (U.S.) 1-800-522-6277  
T (International) (303) 527-5200  
F (303) 530-8549  
[www.rosemount.com](http://www.rosemount.com)

**Emerson Process Management  
Flow**

Neonstraat 1  
6718 WX Ede  
The Netherlands  
T +31 (0)318 495555  
F +31(0) 318 495556  
[www.rosemount.com](http://www.rosemount.com)

**Emerson Process Management**

Asia Pacific Pte Ltd  
1 Pandan Crescent  
Singapore 128461  
T +65 6777 8211  
F +65 6777 0947  
Service Support Hotline: +65 6770 8711  
Email: [Enquiries@AP.EmersonProcess.com](mailto:Enquiries@AP.EmersonProcess.com)  
[www.rosemount.com](http://www.rosemount.com)

**Emerson Process Management  
Latin America**

1300 Concord Terrace, Suite 400  
Sunrise Florida 33323 USA  
T + 1 954 846 5030  
[www.rosemount.com](http://www.rosemount.com)

Standard Terms and Conditions of Sale can be found at [www.rosemount.com/terms\\_of\\_sale](http://www.rosemount.com/terms_of_sale)  
The Emerson logo is a trade mark and service mark of Emerson Electric Co.  
Rosemount and the Rosemount logotype are registered trademarks of Rosemount Inc.  
PlantWeb is a registered trademark of one of the Emerson Process Management group of companies.  
HART and WirelessHART are registered trademarks of the HART Communication Foundation  
Modbus is a trademark of Modicon, Inc.  
All other marks are the property of their respective owners.  
© 2013 Rosemount Inc. All rights reserved.