

Flow Measurement

SITRANS F C

Flow sensor SITRANS FC300

Overview



SITRANS FC300 is a compact Coriolis mass sensor suitable for flow measurement of a variety of liquids and gases.

The sensor offers superior performance in terms of flow accuracy, turn-down ratio and density accuracy. The ease of installation through a „plug & play“ interface ensures optimum performance and operation.

A new designed encapsulation in stainless steel with a surprisingly low weight of only 3.5 kg (7.7 lb), ensures a rigid and robust sensor performance for a wide range of applications.

Benefits

- High accuracy better than 0.1 % of mass flow rate
- Large dynamic turn-down ratio better than 500:1
- Densitometer performance available through a density accuracy better than 0.001 g/cm³ (0.000036 lb/inch³) with a repeatability better than 0.0002 g/cm³ (0.000072 lb/inch³)
- One tube without internal welds, reductions or flow splitters offers optimal hygiene, safety and CIP cleanability for food and beverage and pharmaceutical applications
- Larger wall thickness, ensures optimal life-time and corrosion resistance and high-pressure durability
- Balanced pipe design with little mechanical energy loss, ensures optimal performance and stability under non-ideal and unstable process conditions (pressure, temperature, density-changes etc.).
- 4-wire Pt1000 temperature measurement ensures optimum accuracy on mass flow, density and fraction flow
- Multi-plug electrical connector and SENSORPROM enable true „plug & play“. Installation and commissioning in less than 10 minutes.
- Intrinsically safe Ex design ia IIC as standard
- Sensor pipe available in high-quality stainless steel AISI 316L/1.4435 or Hastelloy C22/2.4602 offering optimum corrosion resistance.
- Rugged and space-saving sensor design in stainless steel matching all applications.
- High-pressure program as standard
- The sensor calibration factor is also valid for gas measurement.

Application

The industry today has an increasing demand for mass flowmeters with a reduced physical size without loss of performance. The meters must be suitable for installation in traditional process industry environment as well as OEM equipment for instance within automotive or appliance industry. Independent of industry application the meter must deliver accurate and reliable measurements. The new and versatile design of the FC300 offers this flexibility.

The main applications for the SITRANS FC300 DN 4 can be found in:

Chemical industry	Liquid and gas measurement in normal as well as corrosive environments
Cosmetic industry	Dosing of essence and fragrances
Pharmaceutical industry	High-speed dosing and coating of pills, filling of ampuls/injectors
Food and beverage industry	Filling, dosing of flavorings, colors and additives, inline density measurement Measurement and dosing of liquid or gaseous CO ₂
Automotive industry	Fuel injection nozzle and pump testing, filling of AC units, engine consumption, paint robots, ABS test-beds

Design

The FC300 sensor consists of a single tube bent in double omega pipe geometry, welded directly to the process connectors at each end. The sensor is available in 2 material configurations, AISI 316L/1.4404 or Hastelloy C22/2.4602 with 1/4"-NPT or G1/4"-ISO process connections.

The enclosure is made of stainless steel AISI 316L/1.4409 with a grade of encapsulation of IP67/NEMA 4. The enclosure has a very robust design and with an overall size of 130 x 200 x 60 mm (5.12" x 7.87" x 2.36") the sensor is very compact and requires only little installation space.

The sensor can be delivered in a standard version with a maximum liquid temperature of 115 °C (239 °F) or a high-temperature version, with raised electrical connector for 180 °C (356 °F).

The sensor can be installed in horizontal or vertical position. The sensor can be mounted directly on any given plane surface or if desired with the enclosed quick release clamp fitting which, along with its compact design and multi-plug electrical connector, will keep installation costs and time to a minimum.

Function

The measuring principle is based on the Coriolis effect. See "System information SITRANS F C Coriolis mass flowmeters".

Integration

The sensor can be connected to all MASS 6000 transmitters for remote installation only.

All sensors are delivered with a SENSORPROM containing all information about calibration data, identity and factory pre-programming of transmitter settings

Installation guidelines for SITRANS FC300 sensor

Horizontal installation as shown in figure A is recommended with gas or liquid applications.

This installation is also recommended when the flow velocity is low (< 1 m/s) or the liquid contains solid particles or air bubbles.

Vertical installation as shown in figure B can be used for liquid or gas applications.

For liquid applications upwards flow is recommended to facilitate the removal of air bubbles and to avoid partly emptying of the sensor.

For gas applications we recommend to place the flow inlet on the sensor high and the outlet low to remove impurities and oil films.

- To ensure that the sensor does not become partly empty, there must be a sufficient counter-pressure on the unit min. 0.1 to 0.2 bar (1.5 to 2.9 psi).
- Mount the sensor on a vibration-free and plane wall or steel frame.
- Locate the sensor low in the system in order to avoid under-pressure in the sensor separating air/gas in the liquid.
- Ensure that the sensor is not emptied of liquid (during normal operation) otherwise incorrect measurement will occur.

Horizontal mounting (recommended) (fig. A)

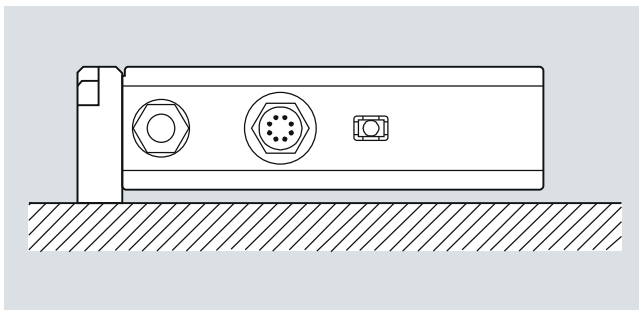

Liquid or gas (low to high flow)

Vertical mounting (fig. B)

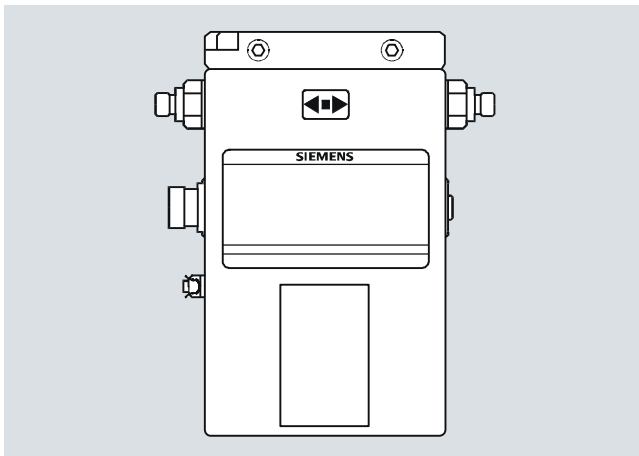

Liquid or gas (medium to high flow)

Technical specifications

Sensor size	DN 4 (1/6")
Mass flow	
Measuring range	0 ... 350 kg/h (0 ... 772 lb/h)
Accuracy, mass flow	0.1 % of rate
Repeatability	0.05 of rate
Max. zero point error	0.010 kg/h (0.022 lb/h)
Density	
Density range	0 ... 2.9 g/cm ³ (0 ... 0.105 lb/inch ³)
Density error	
• Stainless steel	0.007 g/cm ³ (0.00025 lb/inch ³)
• Hastelloy C22/2.4602	0.0025 g/cm ³ (0.00009 lb/inch ³)
Repeatability error	0.0002 g/cm ³ (0.0000072 lb/inch ³)
Temperature	
Standard	-40 ... +115 °C (-40 ... +239 °F)
High-temperature version	-40 ... +180 °C (-40 ... +356 °F)
Temperature error	0.5 °C (0.9 °F)
BRIX	
Measuring range	0 ... 100 BRIX
Brix error	0.3 BRIX
Inside pipe diameter	
Stainless steel version	3.5 mm (0.14")
Hastelloy version	3.0 mm (0.12")
Pipe wall thickness	
Stainless steel version	0.25 mm (0.0098")
Hastelloy version	0.5 mm (0.0196")
Liquid pressure measuring pipe¹⁾	
Stainless steel	130 bar (1885 psi) at 20 °C (68 °F)
Hastelloy C22/2.4602	410 bar (5945 psi) at 20 °C (68 °F)
Materials	Stainless steel AISI 316L/1.4435
Measuring pipe and connection	Hastelloy C22/2.4602
Enclosure²⁾	
Material	Stainless steel AISI 316L/1.4404
Enclosure grade	IP67/NEMA4
Connection thread	
ISO 228/1	G 1/4" male
ANSI/ASME B1.20.1	1/4" NPT male
Ex approval	Ex ia IIC T3-T6 05ATEX138072X c-UL-us Class 1 Div. 1, Gr. A, B, C, D
Weight	3.5 kg (7.7 lb)
Dimensions	135 x 205 x 58 mm (5.31" x 8.07" x 2.28")

¹⁾ According to DIN 2413, DIN 17457

²⁾ Housing is not rated for pressure containment.

Flow Measurement

SITRANS F C

Flow sensor SITRANS FC300

3

Selection and Ordering data	Order No.	Order code
SITRANS F C Flow sensors	7ME4400-	
SITRANS FC300 DN 4 (1/6") sensor		
Pipe material and temperature		
Stainless steel AISI 316L/1.4435	1 G	
115 °C (239 °F)	1 H	
180 °C (356 °F)		
Hastelloy C22/2.4602	2 G	
115 °C (239 °F)	2 H	
180 °C (356 °F)		
Pressure		
PN 100	D	
PN 130 (316L)	G	
PN 410 (C22)	Q	
Process connection		
Pipe thread		
G 1/4" male	1 0	
1/4" NPT male	1 1	
Configuration		
Standard		1
Density ¹⁾		2
BRIX/PLATO		3
Fraction (specification required)		9
		N 0 Y
Transmitter compact mounted on sensor		
No transmitter, sensor and adapter only		A
MASS 6000, Ex d, stainless steel enclosure, 1 current, 1 freq./pulse and 1 relay output, 24 V AC/DC with Ex de [ia/ib] T3 -T6 Ex-approval		B
MASS 6000, IP67, Polyamide enclosure, cable glands M20, 1 current, 1 freq./pulse and 1 relay output, 24 V AC/DC		C
MASS 6000, IP67, Polyamide enclosure, cable glands M20, 1 current, 1 freq./pulse and 1 relay output, 115/230 V AC 50/60 Hz		D
MASS 6000, IP67, Polyamide enclosure, cable glands 1/2" NPT, 1 current, 1 freq./pulse and 1 relay output, 24 V AC/DC		E
MASS 6000, IP67, Polyamide enclosure, cable glands 1/2" NPT, 1 current, 1 freq./pulse and 1 relay output, 115/230 V AC 50/60 Hz, 1/2" NPT		F
Cable		
No cable		A
5 m (16.4 ft) cable		B
10 m (32.8 ft) cable		C
25 m (82 ft) cable		D
50 m (164 ft) cable		E
75 m (246 ft) cable		F
150 m (492 ft) cable		G
Calibration		
Standard calibration 3 flow x 2 points		1
Standard calibration matched pair 3 flow x 2 points		2
Accredited calibration matched pair 5 flow x 2 points (DANAK)		3
Extended calibration customer-specified select Y60, Y61, Y62 or Y63 (see additional information)		8

¹⁾ Density calibration on request. Contact Siemens for details.

Selection and Ordering data	Order code
Additional information	
Please add "-Z" to Order No. and specify Order code(s) and plain text.	
Pressure testing certificate PED: 97/23/EC	C11
Material certificate EN 10204-3.1	C12
Welding certificate NDT-Penetrant: ISO 3452	C13
Factory certificate according to EN 10204 2.2	C14
Factory certificate according to EN 10204 2.1	C15
Tag name plate, stainless steel	Y17
Tag name plate, plastic	Y18
Customer-specific transmitter setup	Y20
Customer-specified, matched pair (5 x 2)	Y60
Customer-specified calibration (5 x 2)	Y61
Customer-specified, matched pair (10 x 1)	Y62
Customer-specified calibration (10 x 1)	Y63
Cleaned for oil and grease	Y80
Special version	Y99

Operating instructions for SITRANS F C FC300

Description	Order No.
• English	A5E00698213
• German	A5E00728101
• Spanish	A5E00746629
• French	A5E00746625

This device is shipped with a Quick Start guide and a CD containing further SITRANS F literature.

All literature is also available for free at:
<http://www.siemens.com/flowdocumentation>

Accessories

Description	Order No.
Cable with multiple plug Standard blue cable between MASS 6000 and MASS 2100, 5 x 2 x 0.34 mm ² twisted and screened in pairs. Temperature range -20 °C ... +110 °C (-4 °F ... +230 °F)	
• 5 m (16.4 ft)	FDK:083H3015
• 10 m (32.8 ft)	FDK:083H3016
• 25 m (82 ft)	FDK:083H3017
• 50 m (164 ft)	FDK:083H3018
• 75 m (246 ft)	FDK:083H3054
• 150 m (492 ft)	FDK:083H3055



Spare parts

Description	Order No.
Multiple plug for cable mounting	FDK:083H5056
2 kB SENSORPROM unit (Sensor Serial No. and Order No. must be specified by ordering)	FDK:083H4410
Mounting bracket in AISI 304	A5E02590439
Demo suitcase including MASS 6000, FC300 (DN 4), and HART module	A5E00789737



Characteristic curves

Pressure drop

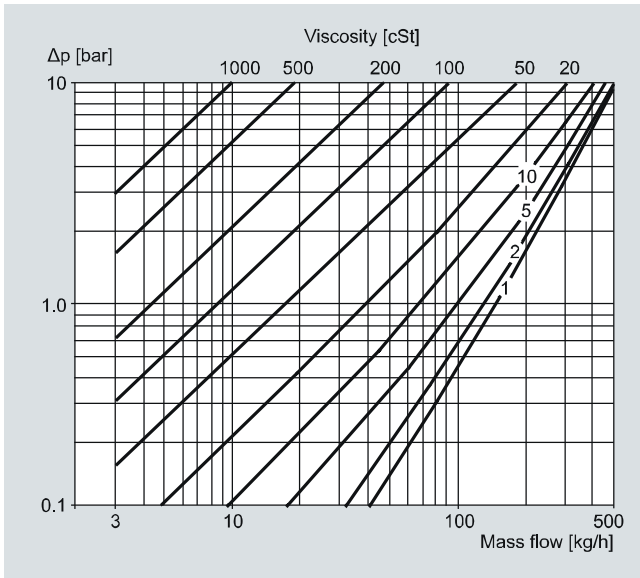

Stainless steel 316L/1.4404

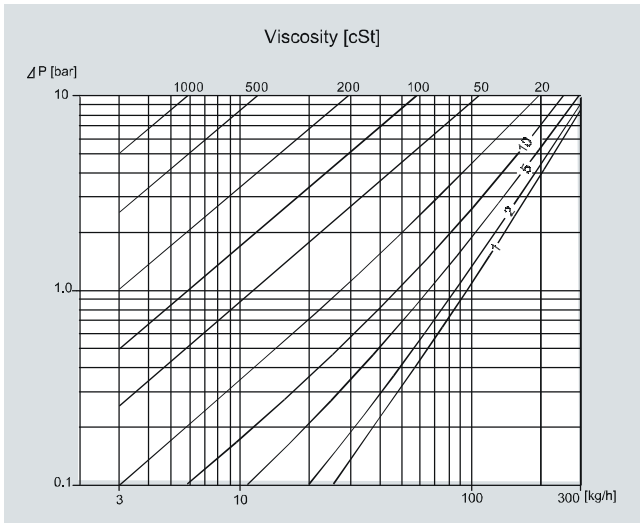

Hastelloy C22/2.4602

Flow Measurement

SITRANS F C

Flow sensor SITRANS FC300

Dimensional drawings

SITRANS FC300 DN 4

3

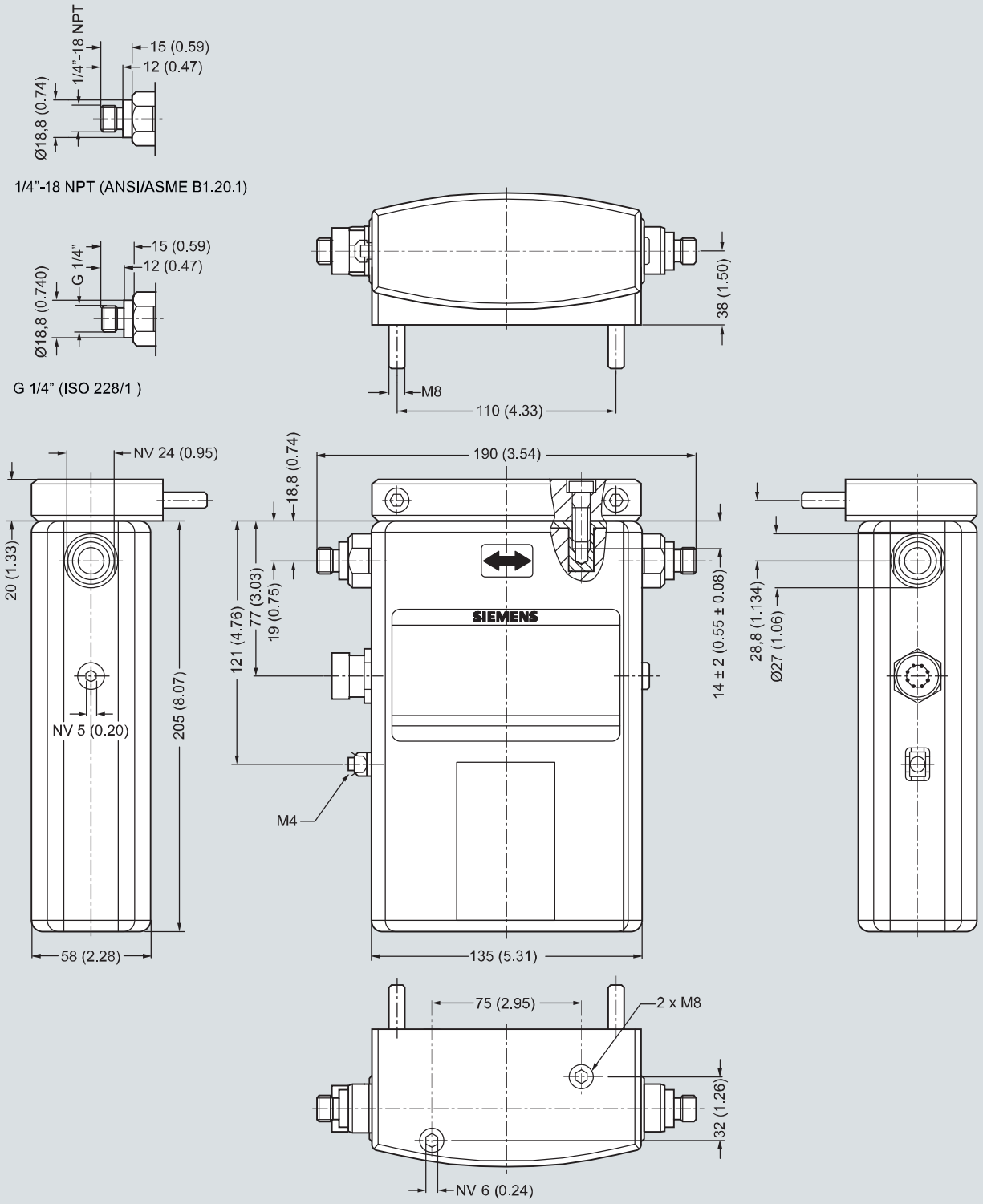

SITRANS FC300, dimensions in mm (inch)