



# Flow measurement

## SITRANS F O delta p - Primary differential pressure devices

### Technical description

#### Primary differential pressure devices to DIN EN ISO 5167

		Nominal diameters	Nominal pressure
	<b>Orifice plates with annular chambers</b>	EN: DN 50 ... DN 1000 ASME: 2 inch ... 40 inch	EN: PN 6 ... PN 100 ASME: Class 150 ... 600
	<b>Orifice plates with single tapplings</b>	EN: DN 50 ... DN 500 ASME: 2 inch ... 20 inch	EN: PN 6 ... PN 315 ASME: Class 150 ... 2500
	<b>Metering pipe</b> • Orifice plate with annular chambers, mounted between flanges	EN: DN 10 ... DN 50 ASME: ½ inch ... 2 inch	EN: PN 10 ... PN 100 ASME: Class 150 ... 600

#### Further products for the complete setup for flow measurements with a primary differential pressure device,

e. g. an orifice plate

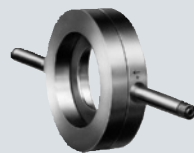

+

For **compensation vessels** (for steam), see chapter 1

For **threaded flange pairs**, see chapter 1

+

For **initial shut-off valves**, see chapter 1

+

For **valve manifolds**, see chapter 1 e. g.

5-spindle valve manifold or



Valve manifold combination DN 8 for vapor measurement

+

For **SITRANS P DS III differential pressure transmitter**, see chapter 1

Measuring cell options:  
20, 60, 250, 600 and 1600 mbar



#### Overview

Primary differential pressure devices are standardized mechanical flow sensors, often also referred to as differential pressure transducers. The primary differential pressure devices are calculated and manufactured according to DIN EN ISO 5167.

Through constriction of the line diameter in the pressure device, the flow rate creates a differential pressure that is converted with the help of a differential pressure transmitter into a proportional current signal or flow value. The assignment of differential pressure to flow is created by means of a "calculation of the primary differential pressure device".

Primary differential pressure devices are suitable for single-phase media such as gas, vapor and liquids without solid components.

#### Requirement when ordering a primary differential pressure device

Always quote the orifice plate calculation and the classification according to the pressure equipment directive 97/23/EC (PED) when placing an order.

#### Orifice plate calculation - calculation protocol

For the "orifice plate calculation" service, you need to fill out the "Questionnaire for calculation of a primary differential pressure device according to DIN EN ISO 5167". The intelligent "SITRANS F O questionnaire online" can be found in the PIA Life Cycle Portal at <http://www.siemens.com/pia-portal>.

For this purpose, you need to specify all the data of the measuring point, medium, process and pipe data, as well as details of installation conditions, flow conditions, permissible pressure losses and accuracy requirements.

We will be unable to carry out the calculation if there are any data missing. A calculation protocol with a consecutive number documents the calculation of the orifice plate. We require this calculation protocol from the customer for manufacturing purposes. It is to be included in the order for the orifice plate.

#### Important note:

The "Orifice Plate Calculation with Preparation of a Calculation Protocol" service is a separate process, and must be carried out before the orifice plate is ordered.

The calculation protocol issued by the customer is to be included in the order for the orifice plate.

## SITRANS F O delta p - Primary differential pressure devices

## Technical description

3

**Classification in accordance with pressure equipment directive 97/23/EC (PED)**

The pressure equipment directive must also be applied to the Orifice portfolio for use in Europe.

In compliance with the pressure equipment directive, equipment is divided into categories I to III or Article 3 paragraph 3 according to danger potential (medium/pressure/volume/nominal diameter).

Submission of this design data in accordance with pressure equipment directive 97/23/EC is mandatory for ordering and manufacture, and must be specified by customers in the orifice plate order.

The Order No. of the orifice plate contains the relevant Category I, II, III or Article 3 paragraph 3 in the order code.

Detailed information is available under "Pressure equipment directive 97/23/EC".

**How to order the "Orifice plate with appended calculation protocol" product**

To order an orifice plate, you need to supply the following data:

- Complete Order No. of the orifice plate, including the respective order code "Manufacture according to pressure equipment directive":
  - Category I, II, III or Article 3 paragraph 3 and the design data with Order Codes Y31 to Y35
  - Or without (only available outside Europe!)
- Appended "Calculation Protocol" issued by the customer with Order Code Y21 or Y22, or statement "Orifice plate without calculation" with Order Code Y01

The orifice plate can only be manufactured when it has been passed as a "clean order", i. e. it has been confirmed that the data of the Order No. match the data of the calculation protocol.

**Benefits**

- Primary differential pressure devices are suitable for universal use across the globe.
- Primary differential pressure devices are very robust and can be used in a wide range of nominal diameters.
- Suitable for high temperature and pressure ranges.
- No wet calibration required as they use an internationally standardized flow rate measurement procedure.
- The differential pressure transmitter can be used over a long distance from the measuring location.
- The differential pressure method is well known and has a large installed base.
- The SITRANS P differential pressure transmitter is easy to parameterize again if process data change. They are adapted by recalculating and assigning new parameters to the transmitter or, in the case of the version orifice plate with annular chamber, by using a new orifice disk.

**Application****Power stations**

Measurement of steam, condensate and water.

**Petrochemical industry/Refineries**

Measurement of water, steam and liquid and gas hydrocarbons.

**Chemical industry**

Measurement of various liquid and gas media.

**Oil and gas industries**

Measurement of liquid and gas hydrocarbons.

**Design****Orifice plate with annular chambers**

The version orifice plate with annular chambers comprises two support rings which are connected to the inside of the pipe over an annular chamber and an annular gap. Tapping sockets direct the differential pressure from the support rings to the differential pressure transmitter over shut-off fittings and differential pressure lines.

The orifice disk is inserted between the support rings together with a gasket.

**Orifice plate with single tapplings**

In the version of the orifice plate with single tapplings the orifice plate is a single unit. The inside of the tube is connected to the tapping sockets by two single tapplings.

Both types of orifice plate are installed between two flanges in the pipeline.

**Function****Mode of operation**

The orifice plate creates a differential pressure. The pressure is transferred through the vertical columns of medium in the differential pressure lines to the measuring cell of the differential pressure transmitter. The transmitter converts the pressure signal with square-root characteristic into a flow-proportional current or into a digital signal, e. g. PROFIBUS.

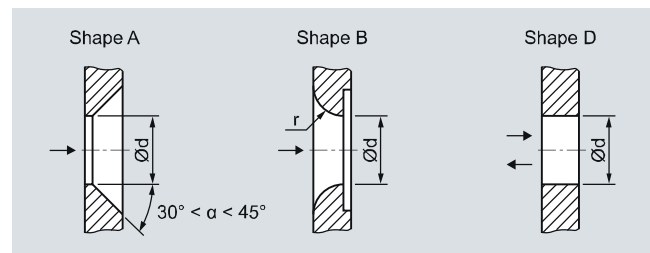
**Types of primary differential pressure devices**

Shapes of the orifice disk aperture

The primary differential pressure devices are calculated and manufactured according to DIN EN ISO 5167. According to this, the application range of the standard orifice disk aperture form A is limited by the Reynolds number. The limits depend on the diameter ratio  $\beta = d/D$ . (D: internal diameter of pipe).

In the case of Reynolds numbers from approx. 500 to  $2.5 \times 10^5$  and DN 40 to DN 150, the orifice disk aperture form B (quarter circle) can be used for slightly less accurate measurements. The profile radius  $r$  depends on the diameter ratio  $\beta$  and results from the calculation of the diameter of the orifice disk aperture  $d$ .

The cylindrical orifice disk aperture form D is used for measurements in both flow directions.

# Flow measurement

## SITRANS F O delta p - Primary differential pressure devices

### Technical description

#### Tapping sockets

Type of threaded connections and welding connections dependent on the measured medium and the nominal pressure of the shut-off fitting

The type of socket connections depends on the measured medium and the nominal pressure of the shut-off fittings; the socket length depends on the nominal diameter (pipe diameter) of the primary differential pressure device and the operating temperature (because of the thermal insulation!). The socket position depends on the measured medium and the flow direction.

- With threaded connection G $\frac{1}{2}$  DIN ISO 228/1, connection dimensions to DIN 19207 Form V, for liquids and gases up to PN 160, for steam up to PN 100
- With threaded connection  $\frac{1}{2}$ -14 NPT male, for version acc. to ASME up to class 600
- With  $\varnothing$  12 mm pipe connection for pipe union with ferrule
- With  $\varnothing$  21.3 mm welding connection for liquids and gases up to PN 400, and for steam up to PN 100, or  $\varnothing$  24 mm for liquids and gases over PN 400, and for steam over PN 100

Other connections on request.

#### Length of tapping sockets

The length of the tapping sockets are specified in DIN 19205, Part 2.

If using with high temperatures and stronger insulations, please quote the insulation thickness and the required length of the tapping sockets when placing an order.

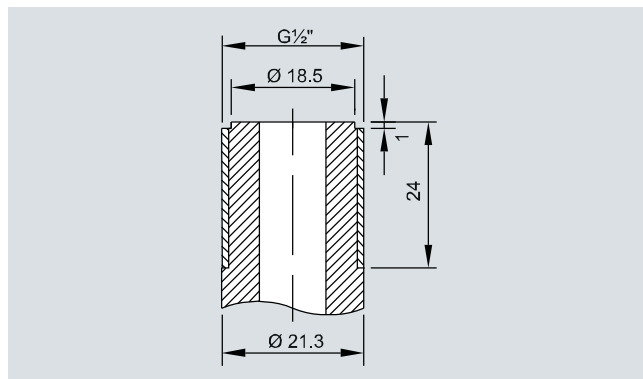

Threaded connections of tapping sockets for liquids and gases up to PN 160, for steam up to PN 100, dimensions in mm

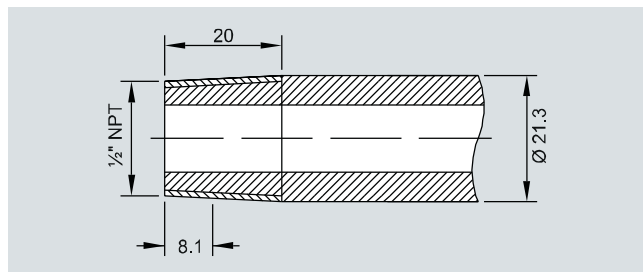

Threaded connection  $\frac{1}{2}$ -14 NPT male, dimensions in mm

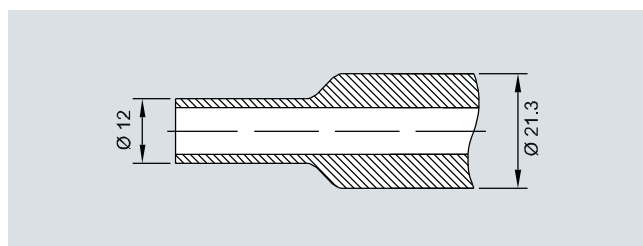

With  $\varnothing$  12 mm pipe for pipe union with ferrule, dimensions in mm

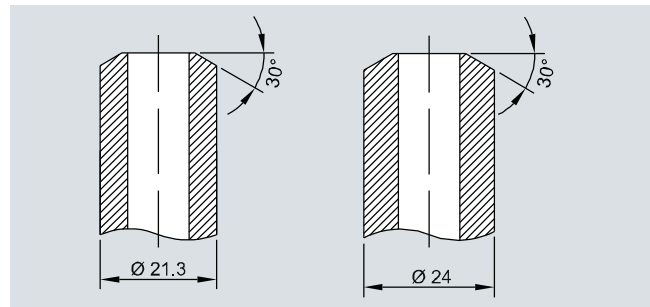

Welding connections of tapping sockets, dimensions in mm

#### Position of the tapping sockets

When measuring liquids and gases, the position of the tapping sockets must comply with the tables according to DIN 19205; when measuring steam, the compensation vessels must be at the same height.

- Horizontal steam lines

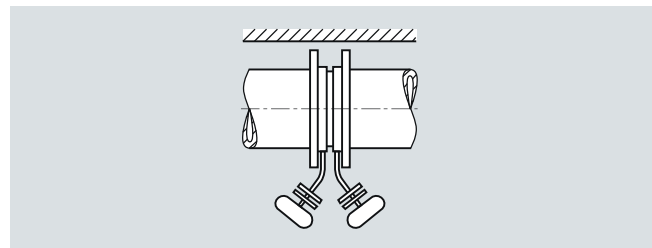

Horizontal steam line in front of a wall with primary differential pressure device and valve combination; with annular chamber orifice plate or single part orifice plate with special length of 65 mm

In the case of horizontal steam lines, straight sockets are arranged opposite each other or, if the pipe is close to a wall, with bent sockets on one side.

- Vertical steam lines

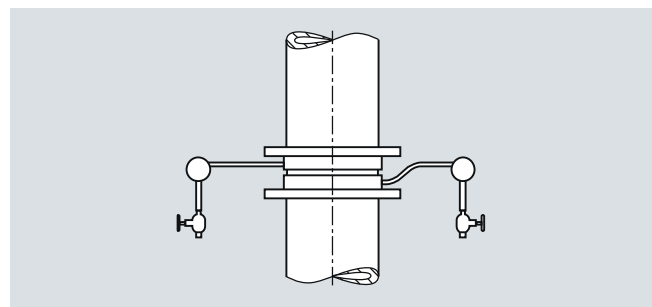

Vertical steam line with primary differential pressure device and valve combination

In the case of vertical and inclined steam lines, the lower socket is bent upwards so that the connection flanges and compensation vessels are also at the same height.

## SITRANS F O delta p - Primary differential pressure devices

## Technical description

Extract from DIN 19205, Part 1, August 1988

No.	Pipe position and flow direction	Position of the tapping sockets	Application
1	Horizontal →	180°	With compensation vessels
2 <sup>1)2)</sup>		0°	
3 <sup>1)2)</sup>			
4	Vertical Rising ↑	90°	Without compensation vessels
5	Falling ↓		
6	Rising ↑	180°	
7	Falling ↓		
10	Horizontal →	<γ <sup>3)</sup>	Without compensation vessels
11	Horizontal, vertical → ↓	180°	
13	Vertical ↓ ↑	90°	

<sup>1)</sup> Not possible with orifice plates with single tappings (overall length 40 mm). Special length of 65 mm is possible.

<sup>2)</sup> Only possible with orifice plates with annular chambers (overall length 65 mm) with bent tapping sockets.

<sup>3)</sup> Angle γ is dependent on the nominal pressure and nominal diameter in accordance with DIN 19 205.

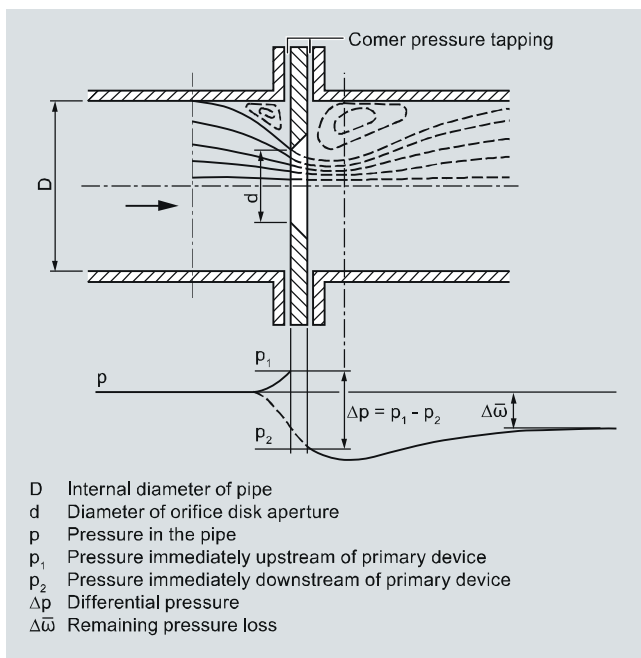
**Principle of the differential pressure method**

Principle of the differential pressure method: Pressure curve at a pipe restriction

A primary differential pressure device is installed at the measuring point to measure the flow. This restricts the pipe and has two connections for sampling the differential pressure. If the properties of the primary device and the medium are known such that

the equation below can be evaluated, the differential pressure is a measure of the absolute flow. No reference measurements are required; the flow measurement can be checked independent of the device manufacturer.

The differential pressure method is based on the law of continuity and Bernoulli's energy equation.

According to the law of continuity, the flow of a moving medium in a pipeline is the same at all points. If the cross-section is reduced at one point, the flow velocity must increase at this point. According to Bernoulli's energy equation, the energy content of a flowing medium is constant and is the total of the static (pressure) and kinetic (movement) energies. An increase in the flow rate therefore results in a reduction in the static pressure (see the figure "Principle of the differential pressure method: Pressure curve at a pipe restriction"). This pressure difference Δp, the so-called differential pressure, is a measure of the flow.

In general the following equation applies:  $q = c\sqrt{\Delta p}$

Where:

- q: flow (q<sub>m</sub>, q<sub>v</sub>) mass flow or volume flow
- Δp: Differential pressure
- c: Factor depending on the dimensions of the pipeline, the type of constriction, the density of the flowing medium etc.

According to this equation, the differential pressure created by the constriction is proportionally equal to the square of the flow (see the figure "Relationship between flow q and differential pressure Δp").

**Integration**

The orifice plate is installed between two flanges in the pipeline. Using compensation vessels (for steam) and initial shut-off valves, the differential pressure of the high-pressure side and low-pressure side is directed through differential pressure lines to a multiple valve manifold and on to the differential pressure transmitter. For media with extreme pressure and temperature fluctuations it makes sense to take an additional measurement of the pressure and temperature in order to correct the flow signal of the transmitter in a subsequent correction computer.

**Selection of mounting point**

The flow measuring regulations DIN EN ISO 5167 not only consider the design of primary differential pressure devices, but also assume that their installation is in accordance with the standard so that the specified tolerances can be retained. The required inlet and outlet pipe sections according to ISO 5167 can be found in the calculation protocol of the respective orifice plate. Configuration of the pipeline should allow for standardized installation (required inlet and outlet pipe section). Particular attention must be paid to ensure that the primary device can be fitted in a sufficiently long straight section of pipe. Bends, valves and similar should be fitted sufficiently far upstream of the primary device to prevent them having a detrimental effect. Primary devices with a large diameter ratio are particularly sensitive to interferences.

**Design of measuring point**

The design of the measuring point depends on the medium and on the spatial conditions. The designs for gas and water only differ with regard to the position of the tapping sockets (see the figure "Measuring setup"); compensation vessels must also be provided for steam.

**Metering pipes**

On lines with small nominal diameters (DN 10 to DN 50) the measurements are influenced by the wall roughness and diameter tolerances of the pipes, far more so than by large nominal diameters. These influences are counteracted by using metering pipes with fitting inlet and outlet pipe sections made of precision pipes. For exact measurements with metering pipes, the flow coefficient C needs to be determined by means of calibration.

# Flow measurement

## SITRANS F O delta p - Primary differential pressure devices

### Technical description

#### Options

Further versions that are available on request:

- Other types of primary differential pressure device: orifice plates without support rings, measurement flange orifice plates, venturi nozzles, classic venturi tubes etc.
- Other nominal diameters and nominal pressures to EN and ASME
- Other lengths, special lengths
- Other materials
- Sealing face with recess or groove
- Flushing rings
- Other tapping sockets, multiple tappings
- Material acceptance test certificates or cold water pressure tests

#### Characteristic curves

The orifice plate has a square-law relationship between differential pressure and flow. A square-root transmitter is required therefore to create a linear flow characteristic.

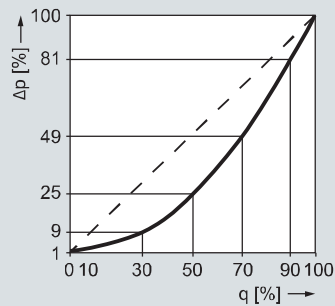

q	0	1	3	5	8	10	15	20	30	40	50	60	70	80	90	100 %
Δp	0	0,01	0,09	0,25	0,64	1	2,25	4	9	16	25	36	49	64	81	100 %

Setting range for application point of square-rooted characteristic for SITRANS P differential pressure transmitter

Relationship between flow  $q$  and differential pressure  $\Delta p$

#### More information

- Standards
- Instruction Manual SITRANS P
- Installation Instructions

# Flow measurement

## SITRANS F O delta p - Primary differential pressure devices

### Technical description

3

- ① Annular chamber orifice plate DN 80, PN 10  
7ME1110-1JE12-1AA1-Z A11
- ② 2 x threaded flange pairs  
2 x 7FM9007-4CA
- ③ 2 x primary shut-off valves  
2 x 7MF9017-1BA
- ④ Three-spindle valve manifold  
7MF9411-5BA-Z B31 + M12
- ⑤ Differential pressure transmitter  
7MF4433-1DA02-1BB6-Z Y02

#### Detail A:

- ⑥ Orifice plate with tapping sockets
- ⑦ Threaded flange pair:
  - ⑦a Hexagon nut
  - ⑦b Gasket
  - ⑦c Threaded flange
  - ⑦d Hexagon bolt
- ⑧ Primary shut-off valve

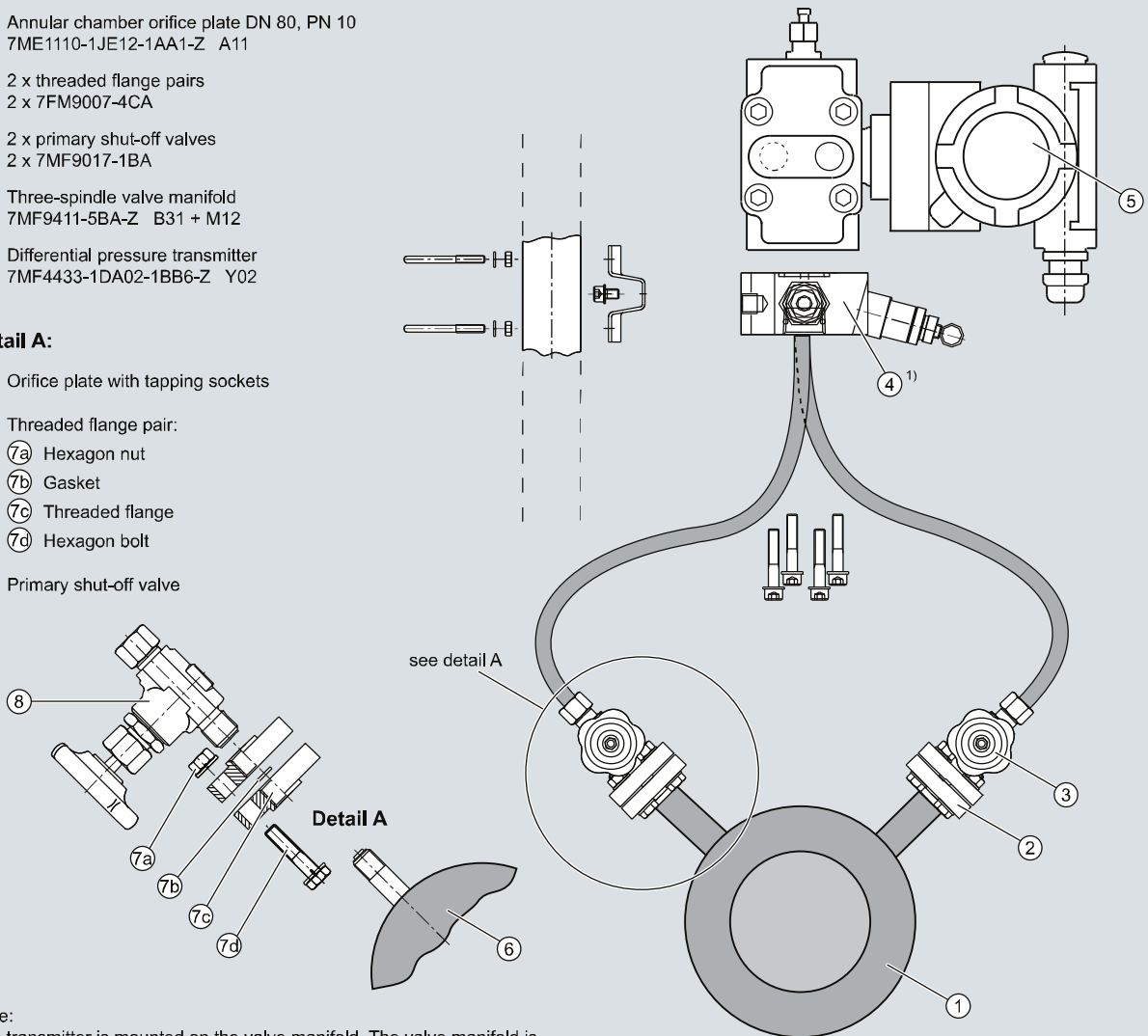

#### Note:

The transmitter is mounted on the valve manifold. The valve manifold is mounted on the pipe (or wall).

Design of measuring point, example: gas measurement (non-corrosive, non-hazardous)

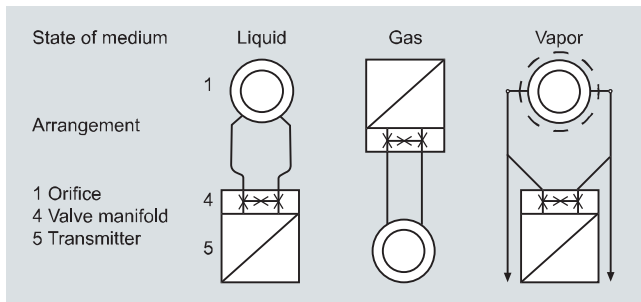

Measuring setup

#### Technical specifications

The technical properties of the orifice plates depend on the device:

- Nominal diameters
- Nominal pressure
- Materials
- Mass
- Temperature limits

#### Accessories

- Compensation vessels
- Threaded flange pairs
- Primary shut-offs
- Valve manifold
- Differential pressure lines (to be provided by the plant owner)
- Gaskets, bolts, screws (to be provided by the plant owner)
- Differential pressure transmitter



# Flow measurement

## SITRANS F O delta p - Primary differential pressure devices

### Pressure equipment directive 97/23/EC

#### Overview

The pressure equipment directive 97/23/EC applies to the alignment of the statutory orders of the European member states for pressure equipment used within its European area of validity. Equipment as defined by the directive includes vessels, pipelines and accessories with a maximum permissible pressure of more than 0.5 bar above atmospheric pressure.

Application of the pressure equipment directive was optional from November 29, 1999 onwards and has been mandatory since May 29, 2002.

#### Categorization according to danger potential

In compliance with the pressure equipment directive, equipment is divided into categories I to III or Article 3 paragraph 3 according to danger potential (medium/pressure/volume/nominal diameter).

The following criteria are decisive for assessment of the danger potential and are also shown in the diagrams (see "Characteristic curves").

Fluid group	Group 1 or 2
Aggregate state	Liquid or gaseous
Type of pressurized equipment	Nominal diameter, pressure or product of pressure and nominal diameter (PS * DN)
• Pipeline	







#### Note

Liquids according to Article 3 are those liquids whose steam pressure is not more than 0.5 bar above standard atmospheric pressure (1013 mbar) at the maximum permissible temperature.

The maximum permissible temperature for the liquids used is the user-defined maximum process temperature. This must be within the limits defined for the equipment.

#### Categorization of media (liquid/gaseous) into fluid groups

In compliance with Article 9, fluids are divided into the following fluid groups:

Group 1			
	<p><b>Explosive</b> R phrases: e. g.: 2, 3 (1, 4, 5, 6, 9, 16, 18, 19, 44)</p>		<p><b>Very toxic</b> R phrases: e. g.: 26, 27, 28, 39 (32)</p>
	<p><b>Extremely flammable</b> R phrases: e. g.: 12 (17)</p>		<p><b>Toxic</b> R phrases: e. g.: 23, 24, 25 (29, 31)</p>
	<p><b>Highly flammable</b> R phrases: e. g.: 11, 15, 17 (10, 30)</p>		<p><b>Oxidizing</b> R phrases: e. g.: 7, 8, 9 (14, 15, 19)</p>

Flammable (where the maximum allowable temperature is above flash-point).

#### Group 2

All fluids not belonging to Group 1.

Also applies to fluids which are e. g. dangerous to the environment, corrosive, dangerous to health, irritant or carcinogenic (if not highly toxic).

#### Conformity rating

Pressure equipment of categories I to IV must comply with the safety requirements of the directive and be assigned the CE symbol.

They must comply with a conformity rating procedure according to Appendix III of the directive.

Pressure equipment according to Article 3 paragraph 3 must be designed and manufactured in agreement with the sound engineering practice SEP applicable in a member country, and must not be assigned a CE symbol (CE symbols from other directives are not affected).

The manufacturer issues a declaration of conformity if the orifice plates are produced for use in the area covered by the PED and are assignable to the categories I, II or III. This declaration of conformity is given to the customer. Its contents depend on the design data of the customer's plant. The design data can only be provided by the operator/customer, and must be specified in the product order for the orifice plate.

Submission of the following design data is mandatory:

- Medium (name)
- Aggregate state (liquid or gas)
- Fluid group 1 or 2
- Max. permissible pressure (PS) of the plant (not PN)
- Max. permissible temperature TS of the plant (not operating temperature)
- Nominal diameter DN

#### Note

Equipment designed for media with a high danger potential (e.g. gases of fluid group 1) may also be used for media with a lower danger potential (e. g. gases of fluid group 2, or liquids of fluid groups 1 and 2).

The pressure equipment directive according to Article 1 paragraph 3 does not apply to equipment such as e. g. mobile offshore plants, ships, aircraft, water supply and waste water networks, nuclear plants, rockets and pipelines outside industrial plants.

# Flow measurement

## SITRANS F O delta p - Primary differential pressure devices

Pressure equipment directive 97/23/EC

### Characteristic curves

#### Gases of fluid group 1

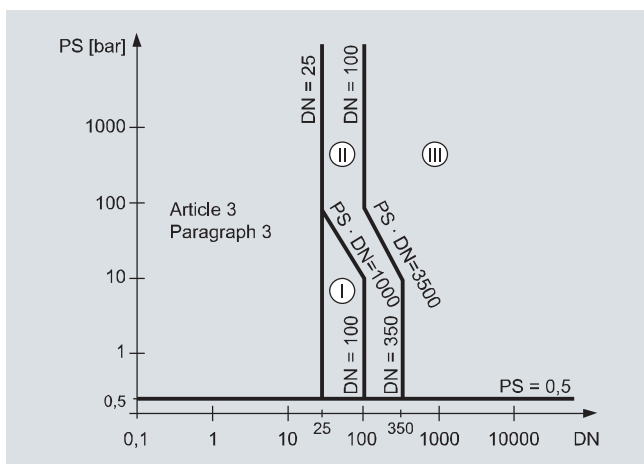

Pipelines according to Article 3 Number 1.3 Letter a) First dash  
Exception: Unstable gases (e.g. acetylene and ethylene) belonging to Categories I and II, must be included in Category III

#### Gases of fluid group 2

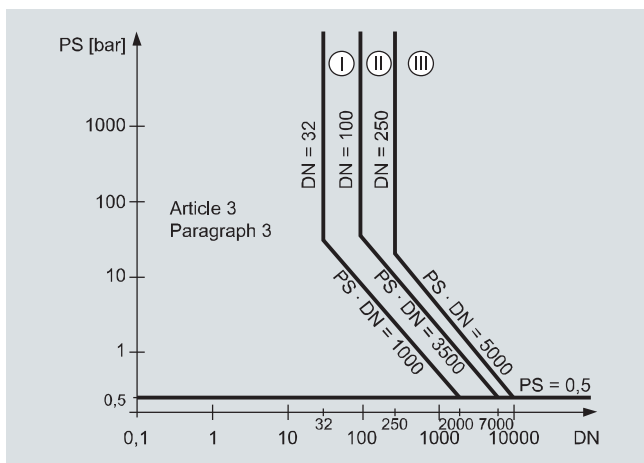

Pipelines according to Article 3 Number 1.3 Letter a) Second dash

Exception: Liquids and steam, at temperatures > 350 °C belonging to Category II must be included in Category III.

#### Liquids of fluid group 1

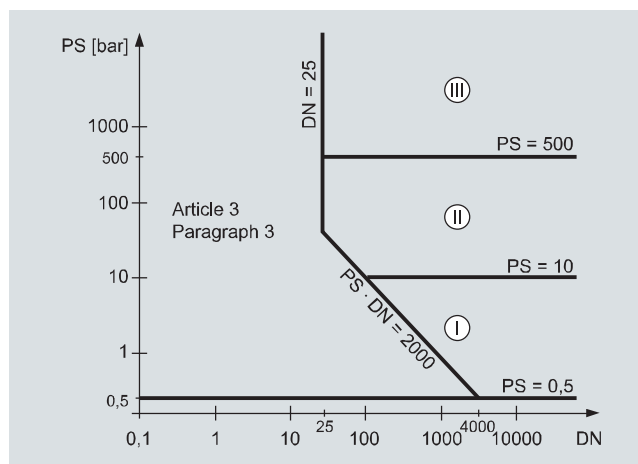

Pipelines according to Article 3 Number 1.3 Letter b) First dash

#### Liquids of fluid group 2

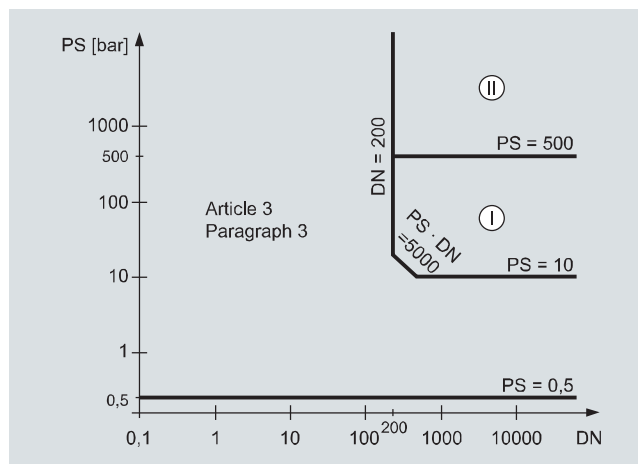

Pipelines according to Article 3 Number 1.3 Letter b) Second dash

3



# Flow measurement

## SITRANS F O delta p - Primary differential pressure devices

### Pressure equipment directive 97/23/EC

#### Design data and product order for orifice plate

If the orifice plate is used in Europe the orifice plate is produced in accordance with the Pressure Equipment Directive 97/23/EC.

In this case the design data are mandatory for the production of an orifice plate and must be specified when ordering.

The required design data are specified in the order number of an orifice plate with the order code Y31 to Y35.

The following design data are mandatory; data can only be provided by the operator/customer:

3

Data for production according to Pressure Equipment Directive 97/23/EC - for use in Europe					
Order code for ordering	<b>Design data</b>				
<b>Y31</b>	<ul style="list-style-type: none"> <li>• <b>Medium/measured medium</b> <span style="float: right;">Name _____</span></li> </ul>				
<b>Y32</b>	<ul style="list-style-type: none"> <li>• <b>Aggregate state</b> <span style="float: right;">Liquid <input type="checkbox"/> Gaseous <input type="checkbox"/></span></li> </ul>				
<b>Y33</b>	<ul style="list-style-type: none"> <li>• <b>Fluid group</b> <span style="float: right;">Group 1 <input type="checkbox"/> <b>All others</b> Group 2 <input type="checkbox"/></span> <ul style="list-style-type: none"> <li>- Explosive</li> <li>- Highly, extremely flammable</li> <li>- Oxidizing</li> <li>- Toxic, highly toxic</li> </ul> </li> </ul>				
<b>Y34</b>	<ul style="list-style-type: none"> <li>• Maximum permissible pressure (<i>not PN</i>) <span style="float: right;">PS<sup>1)</sup> _____ <input type="checkbox"/> bar <input type="checkbox"/> psi</span></li> </ul>				
<b>Y35</b>	<ul style="list-style-type: none"> <li>- at the <b>maximum permissible temperature</b> <span style="float: right;">TS<sup>2)</sup> _____ <input type="checkbox"/> °C <input type="checkbox"/> °F</span></li> </ul> <p><small>1) PS: Setting pressure of the safety mechanism (valve, bursting disk) 2) TS: Range of the temperature limits</small></p>				
The following are already defined by the order number:					
	<ul style="list-style-type: none"> <li>• <b>Nominal diameter</b> <span style="float: right;">DN _____</span></li> <li>• <b>Assignment of the category</b> Annex II of the Pressure Equipment Directive contains 4 diagrams with which the associated category of the primary differential pressure devices can be determined (see page 3/441).</li> </ul> <table style="width: 100%; border: none;"> <tr> <td><input type="checkbox"/> Article 3, Paragraph 3</td> <td><input type="checkbox"/> Category II</td> </tr> <tr> <td><input type="checkbox"/> Category I</td> <td><input type="checkbox"/> Category III</td> </tr> </table>	<input type="checkbox"/> Article 3, Paragraph 3	<input type="checkbox"/> Category II	<input type="checkbox"/> Category I	<input type="checkbox"/> Category III
<input type="checkbox"/> Article 3, Paragraph 3	<input type="checkbox"/> Category II				
<input type="checkbox"/> Category I	<input type="checkbox"/> Category III				

# Flow measurement

## SITRANS F O delta p - Primary differential pressure devices

SITRANS F O questionnaire online

### Overview

#### **SITRANS F O questionnaire online**

For the calculation of a primary differential device in accordance with DIN EN ISO 5167 and for the production of primary differential devices in accordance with the Pressure Equipment Directive 97/23/EC the required data (measuring point and customer-specific data) can be entered in the "SITRANS F O questionnaire online".

The intelligent "SITRANS F O questionnaire online" can be found in the PIA Life Cycle Portal at:  
<http://www.siemens.com/pia-portal>.

All the data required for calculating a primary differential device - orifice plates, nozzles, Venturi nozzles and the classic Venturi tube - can be entered here and attached to the order for calculation of an orifice plate as a Microsoft Excel file.

All the necessary data for calculating a primary differential device are requested menu-driven and can be verified by a check function.

Numerous new features provide the user with essential benefits when using the questionnaire online:

- Clear structure of all necessary parameters
- Menu-driven input of data and values through automatic specification of parameters and units, in accordance with the selected design, the given measured medium and the selected optimization criterion.
- Explanatory and in-depth notes as description and explanation of the parameter
- Numerous input options of customer and measuring point specific supplementary conditions
- Verification of all mandatory input boxes
- Safe data storage of entered customer-specific parameters
- Print preview and print template
- Immediate dispatch of the completed questionnaire online by e-mail

# Flow measurement

## SITRANS F O delta p - Primary differential pressure devices

### Orifice plate with annular chamber

#### Application



Suitable for non-corrosive and corrosive gases, vapors and liquids; permissible operating temperature -10 to +400°C.

#### Design

- Two support rings with replaceable orifice disk form A, B or D (see types of primary differential pressure devices in "Technical description", "Function"); see Ordering data for materials
- Graphite gasket with noncorrosive metal foil insert between orifice disk and support ring outlet

#### Overall length

65 mm to DIN 19205

#### Nominal diameters

EN: DN 50 to DN 1000

ASME: 2 inch to 40 inch

#### Nominal pressure

EN: PN 6 to PN 100

ASME: class 150 to 600

#### Sealing face to the mating flanges

- Plane, sealing face turned, N10/N12 to DIN ISO 1302
- Plane, sealing face turned, N8 to DIN ISO 1302
- Plane, RF (raised faced) for version to ASME

#### Tapping sockets

For the dimensions of the following tapping sockets, see "Function":

- With connection thread G $\frac{1}{2}$  DIN ISO 228/1, connection dimensions to DIN 19207 form V
- With threaded connection  $\frac{1}{2}$ -14 NPT male, for version to ASME
- With  $\varnothing$  12 mm pipe connection for pipe union with ferrule
- With welding connection  $\varnothing$  21.3 mm

See "Technical description" and "Function" for position of the tapping sockets.

#### Dimensional drawings

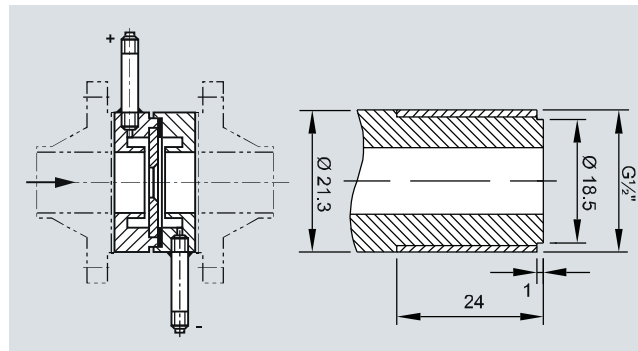

Orifice plate with annular chamber (above); tapping socket with threaded connection (below), dimensions in mm

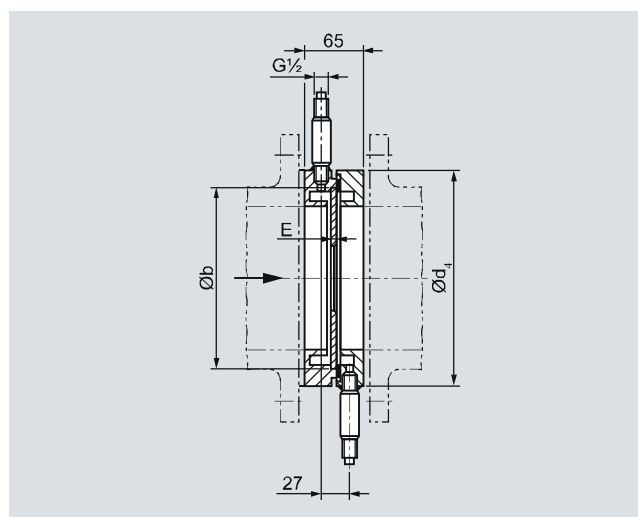

Tapping socket: Socket length is fixed in accordance with the pressure and nominal diameter (DIN 19 205, Part 2).

- Threaded connections of tapping sockets for liquids and gases up to PN 160, for steam up to PN 100, dimensions in mm

Versions for steam lines: See "Technical description", "Function" for position of the tapping sockets.

# Flow measurement

## SITRANS F O delta p - Primary differential pressure devices

### Orifice plate with annular chamber

3

#### Nominal diameter acc. to EN

DN	Inside diameter	External diameter $d_4$ / sealing face: plane, with recess or with groove.						
		PN 6	PN 10	PN 16	PN 25	PN 40	PN 63	PN 100
50	43 ... 55	96	107	107	107	107	113	119
65	59 ... 71	116	127	127	127	127	138	144
80	73 ... 85	132	142	142	142	142	148	154
100	90 ... 108	152	162	162	168	168	174	180
125	114 ... 132	182	192	192	194	194	210	217
150	142 ... 160	207	218	218	224	224	247	257
200	185 ... 211	262	273	273	284	290	309	324
250	237 ... 262	317	328	329	340	352	364	391
300	285 ... 314	373	378	384	400	417	424	458
350	328 ... 362	423	438	444	457	474	486	512
400	380 ... 408	473	489	495	514	546	543	–
500	477 ... 514	578	594	617	624	628	–	–
600	581 ... 610	679	695	734	731	–	–	–
700	686 ... 710	784	810	804	833	–	–	–
800	776 ... 810	890	917	911	942	–	–	–
900	876 ... 910	990	1017	1011	1042	–	–	–
1000	976 ... 1010	1090	1124	1128	1154	–	–	–

Orifice plates with annular chambers for installation between EN flanges to EN 1092-1, dimensions in mm and weights

DN	L				E	Weight (approx. in kg)	
	PN 6	PN 10 ... 25	PN 40	PN 63 ... 100		PN 6 ... 100	With smallest nominal pressure
50	79	79	79	79	2 ± 0.2	2.5	4.5
65	96	96	96	96	2 ± 0.2	3.4	6.4
80	115	115	115	115	4 ± 0.2	4.3	6.9
100	137	137	137	137	4 ± 0.25	4.7	8.6
125	164	164	164	164	4 ± 0.25	6.3	12.4
150	193	193	193	193	4 ± 0.29	7.0	17.0
200	247	247	247	247	4 ± 0.29	10.3	26.2
250	302	302	302	302	4 ± 0.32	13.1	36.6
300	354	354	354	354	4 ± 0.36	17.3	49.0
350	403	403	403	403	4 ± 0.4	25.0	63.0
400	452	452	452	452	4 ± 0.4	28.0	73.8
500	553	563	563	–	6 ± 0.4	36.2	65.9
600	659	659	–	–	6 ± 0.4	42.5	75.6
700	757	762	–	–	8 ± 0.4	51.8	89.5
800	869	875	–	–	8 ± 0.4	61.7	109
900	969	975	–	–	8 ± 0.4	68.3	123
1000	1071	1079	–	–	10 ± 0.4	74.0	148

Orifice plates with annular chambers for installation between EN flanges to EN 1092-1, dimensions in mm and weights (contd.)

# Flow measurement

## SITRANS F O delta p - Primary differential pressure devices

### Orifice plate with annular chamber

#### Nominal diameter acc. to ASME

ASME	External diameter d4 / sealing face: Plane, RF (raised faced)			L			E	Weight (approx. in kg)	
	Class 150	Class 300	Class 600	Class 150	Class 300	Class 600		Class 150 ... 600	With smallest nominal pressure
2 inch	105	111	111	79	79	79	2±0.2	2.5	4.5
2½ inch	124	130	130	96	96	96	2±0.2	3.4	6.4
3 inch	137	149	149	115	115	115	4±0.2	4.3	6.9
4 inch	175	181	194	137	137	137	4±0.2	4.7	8.6
5 inch	197	216	241	164	164	164	4±0.25	6.3	12.4
6 inch	222	251	267	193	193	193	4±0.29	7.0	17.0
8 inch	279	308	321	247	247	247	4±0.29	10.3	26.2
10 inch	340	362	400	302	302	302	4±0.32	13.1	36.6
12 inch	410	422	457	354	354	354	4±0.36	17.3	49.0
14 inch	451	486	492	403	403	403	4±0.4	25.0	63.0
16 inch	514	540	565	452	452	452	4±0.4	28.0	73.8
20 inch	549	597	613	553	563	563	6±0.4	36.2	65.9
24 inch	717	775	790	659	659	–	6±0.4	42.5	75.6

Orifice plates with annular chambers for installation between ASME flanges to ASME B16.5, dimensions in mm and weights

# Flow measurement

## SITRANS F O delta p - Primary differential pressure devices

### Orifice plate with annular chamber

Selection and ordering data	Order No.	Order code	Selection and ordering data	Order No.	Order code
<b>Orifice plate with annular chambers</b>	7 ME 1 1 1 0 -	- 1	<b>Orifice plate with annular chambers</b>	7 ME 1 1 1 0 -	- 1
for mounting between flanges					
Sealing faces to the mating flanges: plane.					
<b><u>Nominal diameter acc. to EN</u></b>					
<b>DN 50</b>			<b>DN 350</b>		
PN 6		1 GA	PN 6		2 HA
PN 10 ... PN 40		1 GE	PN 10		2 HB
PN 63		1 GF	PN 16		2 HC
PN 100		1 GG	PN 25		2 HD
<b>DN 65</b>			PN 40		2 HE
PN 6		1 HA	PN 63		2 HF
PN 10 ... PN 40		1 HE	PN 100		2 HG
PN 63		1 HF	<b>DN 400</b>		
PN 100		1 HG	PN 6		2 JA
<b>DN 80</b>			PN 10		2 JB
PN 6		1 JA	PN 16		2 JC
PN 10 ... PN 40		1 JE	PN 25		2 JD
PN 63		1 JF	PN 40		2 JE
PN 100		1 JG	PN 63		2 JF
<b>DN 100</b>			<b>DN 500</b>		
PN 6		2 AA	PN 6		2 KA
PN 10 and PN 16		2 AC	PN 10		2 KB
PN 25 and PN 40		2 AE	PN 16		2 KC
PN 63		2 AF	PN 25		2 KD
PN 100		2 AG	PN 40		2 KE
<b>DN 125</b>			<b>DN 600</b>		
PN 6		2 BA	PN 6		3 AA
PN 10 and PN 16		2 BC	PN 10		3 AB
PN 25 and PN 40		2 BE	PN 16		3 AC
PN 63		2 BF	PN 25		3 AD
PN 100		2 BG	<b>DN 700</b>		
<b>DN 150</b>			PN 6		3 BA
PN 6		2 CA	PN 10		3 BB
PN 10 and PN 16		2 CC	PN 16		3 BC
PN 25 and PN 40		2 CE	PN 25		3 BD
PN 63		2 CF	<b>DN 800</b>		
PN 100		2 CG	PN 6		3 CA
<b>DN 200</b>			PN 10		3 CB
PN 6		2 EA	PN 16		3 CC
PN 10 and PN 16		2 EC	PN 25		3 CD
PN 25		2 ED	<b>DN 900</b>		
PN 40		2 EE	PN 6		3 DA
PN 63		2 EF	PN 10		3 DB
PN 100		2 EG	PN 16		3 DC
<b>DN 250</b>			PN 25		3 DD
PN 6		2 FA	<b>DN 1000</b>		
PN 10		2 FB	PN 6		3 EA
PN 16		2 FC	PN 10		3 EB
PN 25		2 FD	PN 16		3 EC
PN 40		2 FE	PN 25		3 ED
PN 63		2 FF	<b><u>Nomin. diameter acc. to ASME</u></b>		
PN 100		2 FG	<b>2 inch</b>		
<b>DN 300</b>			Class 150		5 GA
PN 6		2 GA	Class 300		5 GB
PN 10		2 GB	Class 600		5 GC
PN 16		2 GC	<b>2½ inch</b>		
PN 25		2 GD	Class 150		5 HA
PN 40		2 GE	Class 300		5 HB
PN 63		2 GF	Class 600		5 HC
PN 100		2 GG	<b>3 inch</b>		
			Class 150		5 JA
			Class 300		5 JB
			Class 600		5 JC
			<b>4 inch</b>		
			Class 150		6 AA
			Class 300		6 AB



# Flow measurement

## SITRANS F O delta p - Primary differential pressure devices

### Orifice plate with annular chamber

3

Selection and ordering data	Order No.	Order code	Selection and ordering data	Order No.	Order code
<b>Orifice plate with annular chambers</b>	7 ME 1 1 1 0 -	- 1	<b>Orifice plate with annular chambers</b>	7 ME 1 1 1 0 -	- 1
Class 600	6 AC		<b>Tapping sockets</b>		
<b>5 inch</b>			with threaded connection G1/2; for liquids and gases PN 160, for steam PN 100		
Class 150	6 BA		• Opposite one another, straight	A	
Class 300	6 BB		• Opposite one another, bent-up, for vertical pipelines	B	
Class 600	6 BC		• Arranged on one side, for horizontal pipelines	C	
<b>6 inch</b>			With threaded connection 1/2-14 NPT male		
Class 150	6 CA		• Opposite one another, straight	Q	
Class 300	6 CB		• Opposite one another, bent-up, for vertical pipelines	R	
Class 600	6 CC		• Arranged on one side, for horizontal pipelines	S	
<b>8 inch</b>			With pipe Ø 12 mm for pipe union with ferrule, max. 200 °C permissible		
Class 150	6 EA		• Opposite one another, straight	J	
Class 300	6 EB		• Opposite one another, bent-up, for vertical pipelines	K	
Class 600	6 EC		• Arranged on one side, for horizontal pipelines	L	
<b>10 inch</b>			With welding connection Ø 21.3 mm for liquids and gases PN 100 ... PN 400, for steam PN 100		
Class 150	6 FA		• Opposite one another, straight	D	
Class 300	6 FB		• Opposite one another, bent-up, for vertical pipelines	E	
Class 600	6 FC		• Arranged on one side, for horizontal pipelines	F	
<b>12 inch</b>			<b>Shape of orifice disk aperture</b>		
Class 150	6 GA		For flow in one direction (see figure "Shapes of orifice disk aperture")		
Class 300	6 GB		• Orifice plate form A	A	
Class 600	6 GC		• Quarter-circle nozzle form B	B	
<b>14 inch</b>			For flow in both directions		
Class 150	6 HA		• Cylindrical orifice plate form D	D	
Class 300	6 HB				
Class 600	6 HC				
<b>16 inch</b>			<b>Manufactured according to pressure equipment directive</b>		
Class 150	6 JA		None <sup>1)</sup>	0	
Class 300	6 JB		According to Article 3, Paragraph 3	1	
Class 600	6 JC		Design data Y31 to Y35 necessary		
<b>20 inch</b>			According to category 1, 2, 3 with CE marking and EC declaration of conformity	5	
Class 150	6 KA		Design data Y31 to Y35 necessary		
Class 300	6 KB				
Class 600	6 KC				
<b>24 inch</b>					
Class 150	7 AA				
Class 300	7 AB				
Class 600	7 AC				
<b>Special version</b>					
Specify order code and plain text	9 AA 0 0	H 1 Y			
Nominal diameter: ..., nominal pressure: ..., material no.: ... and material name: ...					
<b>Material for non-corrosive media</b>					
Support rings made of P265GH, material no. 1.0425; tapping sockets made of P235GH, material no. 1.0345; orifice disk made of material no. 1.4404, permissible operating temperature -10 to +400 °C	1 2				
<b>Material for corrosive media</b>					
Support rings, tapping sockets and orifice disk made of X 2 CrNiMo 17-12-2, material No. 1,4404; permissible operating temp. -10 to +400 °C	1 5				

## SITRANS F O delta p - Primary differential pressure devices

## Orifice plate with annular chamber

Selection and ordering data	Order code
<b>Further designs</b> Add "-Z" to order no. and specify order code(s) and plain text.	
<b>With Siemens calculation protocol</b> Specify in plain text: No.: ... e. g. no.: 110025240101, Attach calculation protocol to the order	Y21
<b>With third-party calculation</b> Specify in plain text: No.: ... Attach calculation protocol to the order	Y22
<b>Orifice plate without calculation</b> Specify in plain text: Diameter of orifice disk aperture <b>d = ... mm</b> Internal diameter of pipe <b>D=... mm</b> Radius of quarter-circle nozzle <b>r = ... mm</b>	Y01
<b>Design data according to Pressure equipment directive 97/23/EC</b>	
<b>Name of medium</b> Specify in plain text: Medium: ..... e. g. natural gas	Y31
<b>Aggregate state</b> Specify in plain text: Aggregate state: ..... Liquid or gaseous	Y32
<b>Fluid group</b> Specify in plain text: Fluid group: ..... Group 1: hazardous explosive fluid or Group 2: All other fluids	Y33
<b>Max. permissible pressure</b> Specify in plain text: PS = ... in bar or PSI	Y34
<b>Max. permissible temperature</b> Specify in plain text: TS = ... in °C or °F	Y35
<b>Orifice plate degreased</b> for oxygen measurements	
• DN 50 (2") ... DN 150 (6")	A12
• DN 200 (8") ... DN 400 (16")	A13
• DN 500 (20") ... DN 1000 (40")	A14
<b>Material certificate</b> Acceptance test certificate to EN 10204-3.1	C01
<b>Cold water pressure test</b> 1.5 x PN, with acceptance test certificate EN 10204	D11
<b>Orifice disk including gasket</b>	on request
<b>Sealing face of orifice plate with recess or groove</b>	on request

**Note on ordering**

The "calculation protocol" released by the customer with order code Y21 or Y22 must be attached to the order as an appendix or the statement "orifice plate without calculation" will be made with order code Y01

**Scope of delivery**

Two support rings with tapping sockets, one orifice disk, one gasket between orifice disk and support ring.  
Graphite (99.85%) flat gasket with foil insert (1.4401, 0.1 mm). Application for liquids, steam, gases, liquid gases, acids, hydrocarbons, oils and oil products.

**Accessories**

See "SITRANS P measuring instruments for pressure".

# Flow measurement

## SITRANS F O delta p - Primary differential pressure devices

### Orifice plate with single tapping

#### Application

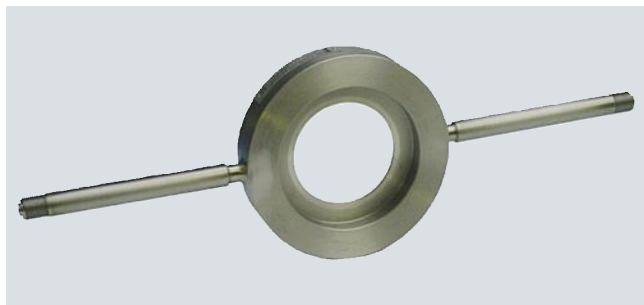

Suitable for non-corrosive and corrosive gases, vapors and liquids; permissible operating temperature -10 to +570 °C.

#### Design

One-piece orifice plate, orifice disk form A, B or D (see types of primary differential pressure devices in "Technical description", "Function"); see Ordering data for materials.

##### **Overall length**

40 mm to DIN 19205

##### **Nominal diameters**

EN: DN 50 to DN 500

ASME: 2 inch to 20 inch

##### **Nominal pressure**

EN: PN 6 to PN 315

ASME: class 150 to 2500

##### **Sealing face to the mating flanges**

- Plane, sealing face turned, N10/N12 to DIN ISO 1302
- Plane, sealing face turned, N8 to DIN ISO 1302
- Plane, RF (raised faced) for versions to ASME

##### **Tapping sockets**

- With connection thread G½ DIN ISO 228/1, with connection dimensions to DIN 19207 form V
- With threaded connection ½-14 NPT male, for version to ASME
- With Ø 12 mm pipe connection for pipe union with ferrule
- With welding connection, Ø 21.3 mm

##### Connection size

The connection size depends on the operating pressure, the temperature of the medium (DIN 19 207 and 19 211) and the medium, e. g.

- For liquids and gases,
  - up to PN 160: Thread G½ or welding connection Ø 21.3 mm
  - from PN 6 and PN 400: Welding connection Ø 21.3 mm
  - > PN 400: Welding connection Ø 24 mm
- For steam
  - up to PN 100: Thread G½ or welding connection Ø 21.3 mm
  - > PN 100: Welding connection Ø 24 mm

See "Technical description" and "Function" for position of the tapping sockets.

# Flow measurement

## SITRANS F O delta p - Primary differential pressure devices

### Orifice plate with single tapping

#### Dimensional drawings

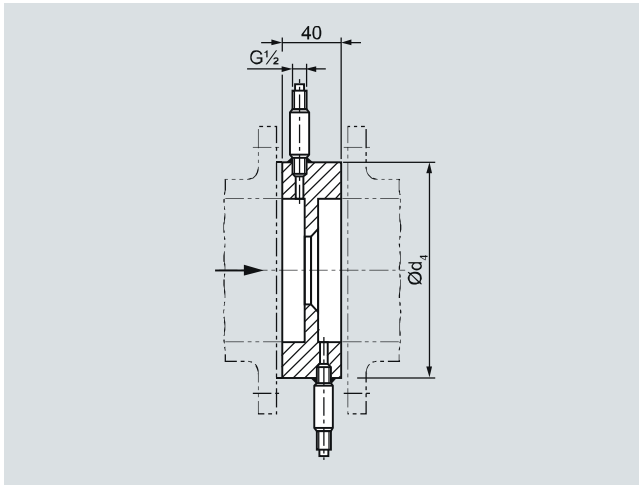

Tapping socket: Socket length is fixed in accordance with the pressure and nominal diameter (DIN 19 205, Part 2), dimensions in mm

- Threaded connections of tapping sockets for liquids and gases up to PN 160, for steam up to PN 100,

Versions for steam lines: See "Technical description", "Function" for position of the tapping sockets.

#### Nominal diameter acc. to EN

DN	Inside diameter	External diameter d <sub>4</sub> / sealing face: plane, with recess or with groove.										Weight (approx. in kg)	
		PN 6	PN 10	PN 16	PN 25	PN 40	PN 63	PN 100	PN 160	PN 250	PN 315	With smallest nominal pressure	With largest nominal pressure
50	45 ... 55	96	107	107	107	107	113	119	119	124	134	1.6	4.0
65	61 ... 71	116	127	127	127	127	138	144	144	154	170	2.2	6.3
80	77 ... 85	132	142	142	142	142	148	154	154	170	190	2.9	7.8
100	94 ... 108	152	162	162	168	168	174	180	180	202	229	3.2	11.5
125	117 ... 132	182	192	192	194	194	210	217	217	242	274	4.3	15.9
150	144 ... 160	207	218	218	224	224	247	257	257	284	311	4.7	20.6
200	188 ... 211	262	273	273	284	290	309	324	324	358	398	7.0	33.7
250	240 ... 262	317	328	329	340	352	364	391	388	442	488	9.0	50.6
300	292 ... 314	373	378	384	400	417	424	458	458	538	–	12.3	37.3
350	331 ... 362	423	438	444	457	474	486	512	–	–	–	17.7	44.6
400	383 ... 408	473	489	495	514	546	543	–	–	–	–	19.8	43.1
500	480 ... 514	578	594	617	624	628	–	–	–	–	–	25.6	46.6

Orifice plates with single tappings for installation between EN flanges to EN 1092-1, dimensions in mm, weights

#### Nominal diameter acc. to ASME

ASME	External diameter d <sub>4</sub> / sealing face: plane, with recess or with groove.			Weight (approx. in kg)	
	Class 150	Class 300	Class 600	With smallest nominal pressure	With largest nominal pressure
2 inch	105	111	111	1.6	4.0
2½ inch	124	130	130	2.2	6.3
3 inch	137	149	149	2.9	7.8
4 inch	175	181	194	3.2	11.5
5 inch	197	216	241	4.3	15.9
6 inch	222	251	267	4.7	20.6
8 inch	279	308	321	7.0	33.7
10 inch	340	362	400	9.0	50.6
12 inch	410	422	457	12.3	37.3
14 inch	451	486	492	17.7	44.6
16 inch	514	540	565	19.8	43.1
20 inch	549	597	613	25.6	46.6

Orifice plates with single tappings for installation between ASME flanges to ASME B 16.5, dimensions in mm and weights

# Flow measurement

## SITRANS F O delta p - Primary differential pressure devices

### Orifice plate with single tapping

3

Selection and ordering data	Order No.	Order code	Selection and ordering data	Order No.	Order code
<b>Orifice plate with single tap-pings</b>	<b>7 ME 1 1 2 0 -</b>	<b>- 1</b>	<b>Orifice plate with single tap-pings</b>	<b>7 ME 1 1 2 0 -</b>	<b>- 1</b>
for mounting between flanges					
Sealing faces to the mating flanges: plane.					
<b><u>Nominal diameter acc. to EN</u></b>					
<b>DN 50</b>			<b>DN 250</b>		
PN 6		1 GA	PN 6		2 FA
PN 10 ... PN 40		1 GE	PN 10 and PN 16		2 FC
PN 63		1 GF	PN 25		2 FD
PN 100 and PN 160		1 GH	PN 40		2 FE
PN 250		1 GJ	PN 63		2 FF
PN 315		1 GK	PN 100 and PN 160		2 FH
<b>DN 65</b>			PN 250		2 FJ
PN 6		1 HA	PN 315		2 FK
PN 10 ... PN 40		1 HE	<b>DN 300</b>		
PN 63		1 HF	PN 6		2 GA
PN 100 and PN 160		1 HH	PN 10		2 GB
PN 250		1 HJ	PN 16		2 GC
PN 315		1 HK	PN 25		2 GD
<b>DN 80</b>			PN 40		2 GE
PN 6		1 JA	PN 63		2 GF
PN 10 ... PN 40		1 JE	PN 100 and PN 160		2 GH
PN 63		1 JF	<b>DN 350</b>		
PN 100 and PN 160		1 JH	PN 6		2 HA
PN 250		1 JJ	PN 10		2 HB
PN 315		1 JK	PN 16		2 HC
<b>DN 100</b>			PN 25		2 HD
PN 6		2 AA	PN 40		2 HE
PN 10 and PN 16		2 AC	PN 63		2 HF
PN 25 and PN 40		2 AE	PN 100		2 HG
PN 63		2 AF	<b>DN 400</b>		
PN 100 and PN 160		2 AH	PN 6		2 JA
PN 250		2 AJ	PN 10		2 JB
PN 315		2 AK	PN 16		2 JC
<b>DN 125</b>			PN 25		2 JD
PN 6		2 BA	PN 40		2 JE
PN 10 and PN 16		2 BC	PN 63		2 JF
PN 25 and PN 40		2 BE	<b>DN 500</b>		
PN 63		2 BF	PN 6		2 KA
PN 100 and PN 160		2 BH	PN 10		2 KB
PN 250		2 BJ	PN 16		2 KC
PN 315		2 BK	PN 25		2 KD
<b>DN 150</b>			PN 40		2 KE
PN 6		2 CA	<b><u>Nominal diameter acc. to ASME</u></b>		
PN 10 and PN 16		2 CC	<b>2 inch</b>		
PN 25 and PN 40		2 CE	Class 150		5 GA
PN 63		2 CF	Class 300		5 GB
PN 100 and PN 160		2 CH	Class 600		5 GC
PN 250		2 CJ	<b>2½ inch</b>		
PN 315		2 CK	Class 150		5 HA
<b>DN 200</b>			Class 300		5 HB
PN 6		2 EA	Class 600		5 HC
PN 10 and PN 16		2 EC	<b>3 inch</b>		
PN 25		2 ED	Class 150		5 JA
PN 40		2 EE	Class 300		5 JB
PN 63		2 EF	Class 600		5 JC
PN 100 and PN 160		2 EH	<b>4 inch</b>		
PN 250		2 EJ	Class 150		6 AA
PN 315		2 EK	Class 300		6 AB
			Class 600		6 AC
			<b>5 inch</b>		
			Class 150		6 BA
			Class 300		6 BB
			Class 600		6 BC

# Flow measurement

## SITRANS F O delta p - Primary differential pressure devices

### Orifice plate with single tapping

Selection and ordering data	Order No.	Order code	Selection and ordering data	Order No.	Order code
<b>Orifice plate with single tapplings</b>	7 ME 1 1 2 0 -	- 1	<b>Orifice plate with single tapplings</b>	7 ME 1 1 2 0 -	- 1
<b>6 inch</b>			<b>Tapping sockets</b>		
Class 150	6 CA		with threaded connection G $\frac{1}{2}$ ; for liquids and gases PN 160, for steam PN 100		
Class 300	6 CB		• Opposite one another, straight	A	
Class 600	6 CC		• Opposite one another, bent- up, for vertical pipelines	B	
<b>8 inch</b>			• Any arrangement of tapping sockets (specify angle in plain text -Z Y02)	G	
Class 150	6 EA		With threaded connection $\frac{1}{2}$ -14 NPT male		
Class 300	6 EB		• Opposite one another, straight	Q	
Class 600	6 EC		• Opposite one another, bent- up, for vertical pipelines	R	
<b>10 inch</b>			• Any arrangement of tapping sockets (specify angle in plain text -Z Y02)	T	
Class 150	6 FA		With pipe $\varnothing$ 12 mm for pipe union with ferrule, max. 200 °C permissible		
Class 300	6 FB		• Opposite one another, straight	J	
Class 600	6 FC		• Opposite one another, bent- up, for vertical pipelines	K	
<b>12 inch</b>			• Any arrangement of tapping sockets (specify angle in plain text -Z Y02)	M	
Class 150	6 GA		With welding connection $\varnothing$ 21.3 mm; for liquids and gases PN 100 ... 400, for steam PN 100 or $\varnothing$ 24 mm; for liquids and gases over PN 400, for steam over PN 100		
Class 300	6 GB		• Opposite one another, straight	D	
Class 600	6 GC		• Opposite one another, bent- up, for vertical pipelines	E	
<b>14 inch</b>			• Any arrangement of tapping sockets (specify angle in plain text -Z Y02)	H	
Class 150	6 HA		<b>Shape of orifice disk aper- ture</b>		
Class 300	6 HB		(see figure "Shapes of orifice disk aperture")		
Class 600	6 HC		For flow in one direction		
<b>16 inch</b>			• Orifice plate form A	A	
Class 150	6 JA		• Quarter-circle nozzle form B	B	
Class 300	6 JB		For flow in both directions		
Class 600	6 JC		• Cylindrical orifice plate form D	D	
<b>20 inch</b>			<b>Manufactured according to pressure equipment directive</b>		
Class 150	6 KA		None <sup>1)</sup>	0	
Class 300	6 KB		According to Article 3, Para- graph 3	1	
Class 600	6 KC		Design data Y31 to Y35 neces- sary	5	
<b>Special version</b>			According to category 1, 2, 3 with CE marking and EC dec- laration of conformity Design data Y31 to Y35 neces- sary.		
Specify order code and plain text	9 AA 0 0	H 1 Y			
Nominal diameter: ..., nominal pressure: ... material no.: ... and material name: ...					
<b>Material for corrosive media</b>					
Orifice plate and tapping socket made of X 2 CrNiMo 17-12-2, material no. 1,4404; permissible operating temp. -10 to +400 °C	2 3				
<b>Material for non-corrosive media</b>					
Orifice plate and tapping socket made of 13 CrMo 4-5, material no. 1,7335; permissible operating temp. -10 to +570, high temperature	2 4				
Orifice plate made of P265GH, material no. 1.0425; tapping sockets made of P235GHTC2, material no. 1.0345; metering edge with X 15 CrNiMn 18-8, material no. 1.4370, deposition welded; permissible operating temper- ature -10 to +400 °C	2 5				

<sup>1)</sup> Only possible outside Europe.



# Flow measurement

## SITRANS F O delta p - Primary differential pressure devices

### Orifice plate with single tapping

3

Selection and ordering data	Order code
<b>Further designs</b> Add "-Z" to order no. and specify order code(s) and plain text.	
<b>With Siemens calculation protocol</b> Specify in plain text: No.: ... e. g. no.: 110025240101, Attach calculation protocol to the order	Y21
<b>With third-party calculation</b> Specify in plain text: No.: ... Attach calculation protocol to the order	Y22
<b>Orifice plate without calculation</b> Specify in plain text: Diameter of orifice disk aperture <b>d = ... mm</b> Internal diameter of pipe <b>D=... mm</b> Radius of quarter-circle nozzle <b>r = ... mm</b>	Y01
<b>Angle between the tapping sockets</b> Specify in plain text: Angle between the tapping sockets ...°	Y02
<b>Design data according to Pressure equipment directive 97/23/EC</b>	
<b>Name of medium</b> Specify in plain text: Medium: ..... e. g. natural gas	Y31
<b>Aggregate state</b> Specify in plain text: Aggregate state: ..... Liquid or gaseous	Y32
<b>Fluid group</b> Specify in plain text: Fluid group: ..... Group 1: hazardous explosive fluid or Group 2: All other fluids	Y33
<b>Max. permissible pressure</b> Specify in plain text: PS = ... in bar or PSI	Y34
<b>Max. permissible temperature</b> Specify in plain text: TS = ... in °C or °F	Y35
<b>Orifice plate degreased</b> for oxygen measurements	
• DN 50 (2") ... DN 150 (6")	A12
• DN 200 (8") ... DN 400 (16")	A13
• DN 500 (20") ... DN 1000 (40")	A14
<b>Material certificate</b> Acceptance test certificate to EN 10204-3.1	C01
<b>Cold water pressure test</b> 1.5 x PN, with acceptance test certificate EN 10204	D11
<b>Overall length 65 mm</b> (required for tapping sockets arranged on one side)	on request
<b>Orifice disk including gasket</b>	on request
<b>Sealing face of orifice plate with recess or groove</b>	on request

#### Note on ordering

The "calculation protocol" released by the customer with order code Y21 or Y22 must be attached to the order as an appendix or the statement "orifice plate without calculation" will be made with order code Y01.

#### Scope of delivery:

One-part orifice plate with tapping sockets

#### Accessories:

See "SITRANS P measuring instruments for pressure".

# Flow measurement

## SITRANS F O delta p - Primary differential pressure devices

Metering pipe  
with orifice plate and annular chamber

3

### Application



Suitable for non-corrosive and corrosive gases, vapors and liquids; permissible operating temperature -10 to +400 °C.

### Design

Orifice plate with annular chambers consisting of two support rings with replaceable orifice disk form A or B (see types of primary differential pressure devices in "Technical description", "Function"); flanged between inlet and outlet pipe sections with lengths according to DIN 19205.

#### Nominal diameters

- EN: DN 10 to DN 50
- ASME: ½ inch to 2 inch

#### Nominal pressure

- EN: PN 10 to PN 100
- ASME: class 150 to 600

#### Sealing face of the end flanges

- Plane, sealing face turned, N10/N12 to DIN ISO 1302
- Plane, sealing face turned, N8 to DIN ISO 1302
- Plane, RF (raised faced) for versions to ASME

#### Tapping sockets

(For the dimensions of the following tapping sockets, see page 3/436)

- With connection thread G½ DIN ISO 228/1, connection dimensions to DIN 19207 form V
- With threaded connection ½-14 NPT male, for version to ASME
- With Ø 12 mm pipe connection for pipe union with ferrule
- With welding connection, Ø 21.3 mm

For length of tapping sockets for all metering pipe L = 120 mm and position of tapping socket, see "Technical Description" and "Function".

# Flow measurement

## SITRANS F O delta p - Primary differential pressure devices

Metering pipe  
with orifice plate and annular chamber

### Dimensional drawings

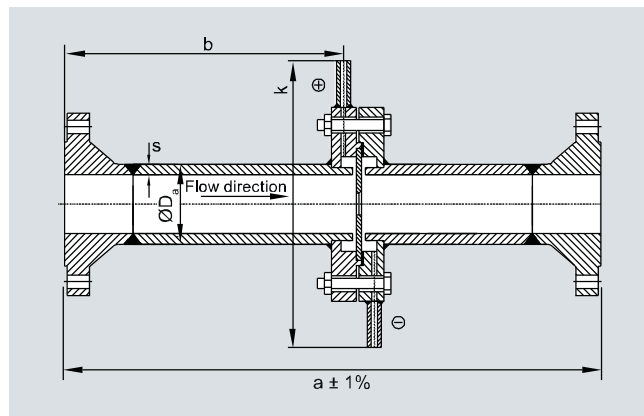

#### Nominal diameter acc. to EN

DN	PN	a	L	k	Pipe <sup>1)</sup> D <sub>a</sub> x s	Weight (approx. kg)
10	10 and 16	400	218	320	16 x 3	4.5
	25 and 40			320		5
	63 and 100			295		6.5
15	10 and 16	550	368	325	20 x 2.5	5
	25 and 40			325		5.5
	63 and 100			300		7.5
20	10 and 16	700	488	335	25 x 2.5	6.5
	25 and 40					7
25	10 and 16	900	638	310	30 x 2.5	8
	25 and 40					9
	63 and 100					14
32	10 and 16	1100	788	320	38 x 3	11.5
	25 and 40					12.5
40	10 and 16	1300	988	330	48.3 x 3.6 oder 50 x 5	13
	25 and 40			330		15
	63 and 100			335		25
50	10 and 16	1500	1188	340	60 x 5	20
	25 and 40			340		22
	63			345		34
	100			345		34

Metering pipes with orifice plates and annular chambers for installation between EN flanges to EN 1092.1, dimensions in mm and weights

<sup>1)</sup> The stated pipe dimensions may vary, depending on availability. The pipe dimensions used can be found in the calculation for primary differential pressure devices and/or in the order confirmation.

#### Nominal diameter acc. to ASME

ASME	PN	a	L	k	Pipe <sup>1)</sup> D <sub>a</sub> x s	Weight (approx. kg)
½ inch	Class 150	550	368	297	20 x 2.5	5
	Class 300			307		5.5
	Class 600			307		7.5
¾ inch	Class 150	700	488	297	25 x 2.5	6.5
	Class 300			307		7
	Class 600			307		8
1 inch	Class 150	900	638	307	30 x 2.5	8
	Class 300			313		9
	Class 600			313		14
1¼ inch	Class 150	1100	788	316	38 x 3	11.5
	Class 300			322		12.5
	Class 600			322		14
1½ inch	Class 150	1300	988	326	48.3 x 3.6 or 50 x 5	13
	Class 300			335		15
	Class 600			335		25
2 inch	Class 150	1500	1188	345	60 x 5	20
	Class 300			371		22
	Class 600			351		34

Metering pipes with orifice plates and annular chambers for installation between ASME flanges to ASME B 16.5, dimensions in mm and weights

<sup>1)</sup> The stated pipe dimensions may vary, depending on availability. The pipe dimensions used can be found in the calculation for primary differential pressure devices and/or in the order confirmation.

# Flow measurement

## SITRANS F O delta p - Primary differential pressure devices

Metering pipe  
with orifice plate and annular chamber

Selection and ordering data	Order No.
<b>Metering pipe for mounting between flanges for non-corrosive media</b>	7 ME 1 3 1 0 - - 1
<u>Orifice plate with annular chambers mounted between flanges</u> Sealing faces to the mating flanges: plane	
<b>Nominal diameter acc. to EN DN 10</b>	
• PN 10 and PN 16	1 AC
• PN 25 and PN 40	1 AE
• PN 63	1 AF
• PN 100	1 AG
<b>DN 15</b>	
• PN 10 and PN 16	1 BC
• PN 25 and PN 40	1 BE
• PN 63	1 BF
• PN 100	1 BG
<b>DN 20</b>	
• PN 10 and PN 16	1 CC
• PN 25 and PN 40	1 CE
<b>DN 25</b>	
• PN 10 and PN 16	1 DC
• PN 25 and PN 40	1 DE
• PN 63	1 DF
• PN 100	1 DG
<b>DN 32</b>	
• PN 10 and PN 16	1 EC
• PN 25 and PN 40	1 EE
<b>DN 40</b>	
• PN 10 and PN 16	1 FC
• PN 25 and PN 40	1 FE
• PN 63	1 FF
• PN 100	1 FG
<b>DN 50</b>	
• PN 10 and PN 16	1 GC
• PN 25 and PN 40	1 GE
• PN 63	1 GF
• PN 100	1 GG
<b>Nominal diameter acc. to ASME</b>	
<b>½ inch</b>	
• Class 150	5 BA
• Class 300	5 BB
• Class 600	5 BC
<b>¾ inch</b>	
• Class 150	5 CA
• Class 300	5 CB
• Class 600	5 CC
<b>1 inch</b>	
• Class 150	5 DA
• Class 300	5 DB
• Class 600	5 DC
<b>1¼ inch</b>	
• Class 150	5 EA
• Class 300	5 EB
• Class 600	5 EC

Selection and ordering data	Order No.
<b>Metering pipe for mounting between flanges for non-corrosive media</b>	7 ME 1 3 1 0 - - 1
<b>1½ inch</b>	
• Class 150	5 FA
• Class 300	5 FB
• Class 600	5 FC
<b>2 inch</b>	
• Class 150	5 GA
• Class 300	5 GB
• Class 600	5 GC
<b>Special version</b>	
Specify order code and plain text	9 AA 0 0
Nominal diameter: ..., nominal pressure: ...	
material no.: ... and material name: ...	
<b>Material for non-corrosive media</b>	
Orifice disk made of material no. 1.4404; support ring and flange made of material no. 1.0460, pipes and tapping sockets made of material number 1.0345; permissible operating temperature -10 to +400 °C	3 2
<b>Material for corrosive media</b>	
Orifice disk, support rings, pipes and flange made of material no. 1.4404; permissible operating temperature -10 to +400 °C	3 4
<b>Tapping sockets</b>	
with threaded connection G½; for liquids and gases PN 160, for steam PN 100	
• Opposite one another, straight	A
• Opposite one another, bent-up, for vertical pipelines	B
• Arranged on one side, for horizontal pipelines	C
With threaded connection ½-14 NPT male; for liquids and gases PN 160, for steam PN 100	
• Opposite one another, straight	Q
• Opposite one another, bent-up, for vertical pipelines	R
• Arranged on one side, for horizontal pipelines	S
With pipe Ø 12 mm for pipe union with ferrule, max. 200 °C permissible	
• Opposite one another, straight	J
• Opposite one another, bent-up, for vertical pipelines	K
• Arranged on one side, for horizontal pipelines	L
With welding connection Ø 21.3 mm for liquids and gases PN 100 ... PN 400, for steam PN 100	
• Opposite one another, straight	D
• Opposite one another, bent-up, for vertical pipelines	E
• Arranged on one side, for horizontal pipelines	F
	H 1 Y

# Flow measurement

## SITRANS F O delta p - Primary differential pressure devices

### Metering pipe with orifice plate and annular chamber

3

Selection and ordering data	Order No.
<b>Metering pipe for mounting between flanges for non-corrosive media</b>	7 ME 1 3 1 0 - - 1
<b>Shape of orifice disk aperture</b> For flow in one direction (see figure "Shapes of orifice disk aperture") <ul style="list-style-type: none"> <li>Orifice plate form A</li> <li>Quarter-circle nozzle form B</li> </ul> For flow in both directions <ul style="list-style-type: none"> <li>Cylindrical orifice plate form D</li> </ul>	A B D
<b>Manufactured according to pressure equipment directive</b> None <sup>1)</sup>  According to Article 3, Paragraph 3 Design data Y31 to Y35 necessary  According to category 1, 2 with CE marking and EC declaration of conformity Design data Y31 to Y35 necessary	0 1 5

<sup>1)</sup> Only possible outside Europe.

Selection and ordering data	Order code
<b>Further designs</b> Add "-Z" to order no. and specify order code(s) and plain text.	
<b>With Siemens calculation protocol</b> Specify in plain text: No.: ... e. g. no.: 110025240101, Attach calculation protocol to the order	Y21
<b>With third-party calculation</b> Specify in plain text: No.: ... Attach calculation protocol to the order	Y22
<b>Orifice plate without calculation</b> Specify in plain text: Diameter of orifice disk aperture <b>d = ... mm</b> Internal diameter of pipe <b>D=... mm</b> Radius of quarter-circle nozzle <b>r = ... mm</b>	Y01
<b>Design data according to Pressure equipment directive 97/23/EC</b>	
<b>Name of medium</b> Specify in plain text: Medium: ..... e. g. natural gas	Y31
<b>Aggregate state</b> Specify in plain text: Aggregate state: ..... Liquid or gaseous	Y32
<b>Fluid group</b> Specify in plain text: Fluid group: ..... Group 1: hazardous explosive fluid or Group 2: All other fluids	Y33
<b>Max. permissible pressure</b> Specify in plain text: PS = ... in bar or PSI	Y34
<b>Max. permissible temperature</b> Specify in plain text: TS = ... in °C or °F	Y35
<b>Orifice plate degreased</b> for oxygen measurements  • DN 10 (½") ... DN 50 (2")	A12
<b>Material certificate</b> Acceptance test certificate to EN 10204-3.1	C02
<b>Cold water pressure test</b> 1.5 x PN, with acceptance test certificate EN 10204	D11

#### Note on ordering

The "calculation protocol" released by the customer with order code Y21 or Y22 must be attached to the order as an attachment or the statement "orifice plate without calculation" will be made with order code Y01.

#### Scope of delivery:

Orifice plate, comprising two support rings with tapping sockets and one orifice disk, with gaskets between orifice disk and support ring, including screws and bolts.  
Graphite (99.85%) flat gasket with foil insert (1.4401, 0.1 mm).  
Application for liquids, steam, gases, liquid gases, acids, hydrocarbons, oils and oil products.

#### Accessories:

See "SITRANS P measuring instruments for pressure".